

Honeywell

MAXON

MAXON OVENPAK® LE

LOW EMISSIONS, HIGH PERFORMANCE GAS BURNERS

TECHNICAL CATALOG

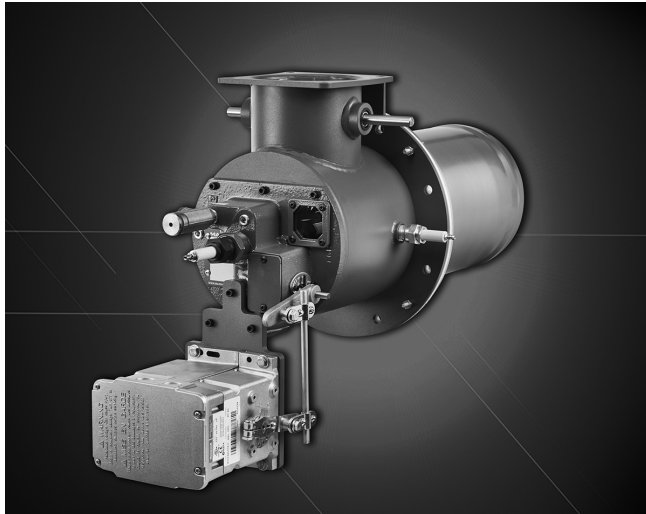

PRODUCT DESCRIPTION

OVENPAK® LE burners are nozzle-mixing gas burners for many industrial, direct-fired applications where clean combustion and high turndown are required. The burners are simple and versatile for use on a variety of heating applications.

The gas flows through the nozzle, then along the inside of the burner cone where combustion air is rapidly mixed with the fuel. This produces a very wide turndown range and a highly stable flame under a variety of operating conditions.

Fuel and air pressures for the burner are balanced (always equal). This unique design provides simple operation and adjustment throughout the operational range of the burner. The balanced pressure feature also makes the OVENPAK® LE Burner resistant to firing chamber pressure fluctuations.

The OVENPAK® LE burner is available in several versions. Packaged burners contain integral combustion air blower with non-sparking paddle wheel-type impeller and linked air and fuel control valves to maintain the gas-air ratio over the full operating range. EB versions include an internal air control valve designed to be connected to an external fuel control valve. The EB version may also be ordered with no control valves.

The OVENPAK® LE burner includes a pilot, spark ignitor, stainless steel discharge sleeve, mixing cone, and provision for a flame sensor.

FEATURES & BENEFITS

- Burns any clean fuel gas
- Operates on low gas supply pressures
- Provides clean combustion with low NOx and CO levels
- Compact burner design provides quick and easy installation
- Balanced pressure design for easy commissioning and adjustment
- Visible ignition action speeds commissioning and maintenance
- High turndown for exceptional process control



32M-01004-03

TABLE OF CONTENTS

Features & Benefits	1
Product description	1
Typical applications	3
Typical emissions	3
Intelligent Model Numbers	4
Specifications of OVENPAK® LE burners	5
OVENPAK® LE 5 burner	5
OVENPAK® LE 10 burner	5
OVENPAK® LE 13 burner	6
OVENPAK® LE 15 burner	6
OVENPAK® LE 30 burner	7
OVENPAK® LE 35 burner	7
OVENPAK® LE 40 burner	7
OVENPAK® LE 45 burner	8
OVENPAK® LE 70 burner	8
OVENPAK® LE EB40, EB65 & EB100 burners	9
Materials of construction	10
Selection criteria	11
OVENPAK® LE burner versions	11
Application details	11
Dimensions and weights	14
OVENPAK® LE packaged burner sizes 5 through 25	14
OVENPAK® LE packaged burner sizes 30 through 45	15
OVENPAK® LE packaged burner size 70	16
OVENPAK® LE burner size EB40	17
OVENPAK® LE burner size EB65	18
OVENPAK® LE burner size EB100	19
Accessory dimensions	20
Installation and operating instructions	25
Application requirements	26
Installation instructions	26
Filter assembly	27
Burner mounting	29
Start-up instructions	31
Maintenance & inspection instructions	31

- 1) Air control valve
- 2) High precision connecting linkage
- 3) Fuel control valve
- 4) Access cover to tuning screw
- 5) Tuning screw

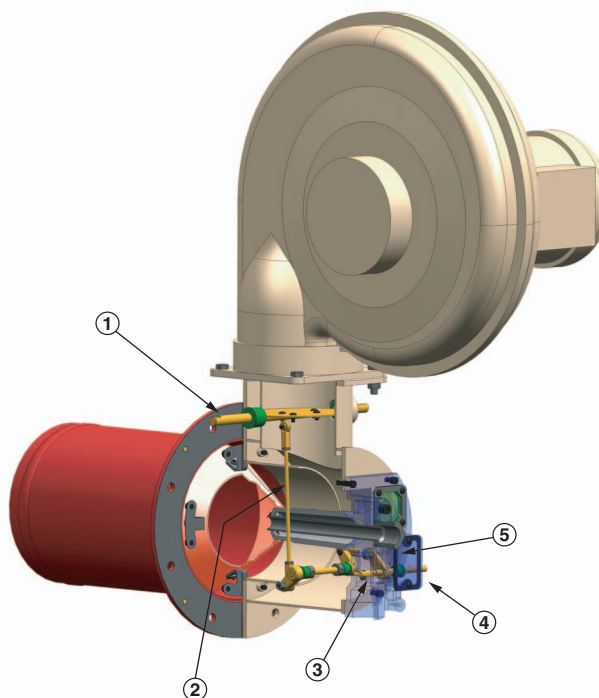

TYPICAL APPLICATIONS

OVENPAK® LE burner applications may include:

- air heating in ovens and dryers
- paint finishing lines
- paper machines
- textile machines
- food baking ovens
- coffee roasters
- grain dryers
- other air heaters

TYPICAL EMISSIONS

MAXON OVENPAK® LE Burners produce low levels of NO_x and CO over a wide range of operation without sacrificing turndown or operational flexibility. Burner emissions can be controlled by adjusting the regulator at high fire position, and by adjusting the ratio tuning screw at lower firing position.

The OVENPAK® LE utilizes advanced mix combustion to effectively suppress the formation of prompt NO_x. CO emissions are held at low levels through effective ratio control with minimal excess air.

Exact emissions performance may vary in your application. Contact MAXON for information on installation-specific estimates and guaranteed values. No guarantee of emissions is intended or implied without specific, written guarantee from MAXON.

INTELLIGENT MODEL NUMBERS

A coded model number is provided on the nameplate of all MAXON OVENPAK® LE Burners to provide a simple method to identify the configuration of the product. This model number ensures accuracy in identifying your product, ordering replacement parts or communicating capabilities.

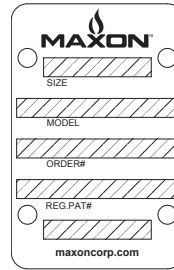

OVENPAK® LE model number													
Series	Model	Size	Pilot	Flame Detection	Fuel	Mixing Cone	Discharge Sleeve	Oven Wall Gasket	Blower Voltage (or Control Valves)	CB&L	Position Switch	Filter/Silencer (Pkgd. only)	Companion Flange (EB100 only)
S	OPLE	1	S	U	N	S	S	N	1	A	A	N	Y

SERIES
S if special - blank if not

MODEL
OPLE - Model ID

SIZE
1 - OPLE 13
2 - OPLE 15
3 - OPLE 25
4 - OPLE 30
5 - OPLE 35
6 - OPLE 40
7 - OPLE 45
8 - OPLE 5
9 - OPLE 10
10 - OPLE 70
A - EB40
B - EB65
C - EB100

PILOT
D - Direct spark
S - Standard pilot

FLAME DETECTION
R - Flame rod
U - Provision for UV scanner

FUEL
N - Natural gas
P - Propane

MIXING CONE
S - Standard

DISCHARGE SLEEVE
C - Short sleeve 310SS
H - High temperature sleeve
R - Refractory lined sleeve 310SS
S - Standard sleeve 310SS

OVEN WALL GASKET
N - No
Y - Yes

BLOWER VOLTAGE - packaged units only
1 - 230/460/3/60 Right motor position std.
2 - 575/3/60 Right motor position std.
3 - 115/1/60 Right motor position std.
4 - 230/460/3/60 Left motor position
5 - 575/3/60 Left motor position
6 - 115/1/60 Left motor position

CONTROL VALVES - EB only
E - External control valves
I - Internal control valves
(no internal linkage)

CB&L
A - No CB&L
B - SMARTLINK CV
C - SMARTLINK MRV
D - Honeywell Mod CB&L only
E - CB&L w/Honeywell Mod Motor
F - CB&L w/Honeywell WP Mod Motor
H - Honeywell R7999 ControLinks
I - SMARTLINK DS DC CV

CB&L - EB40, EB65 & EB100 only:
A - No CB&L
B - SMARTLINK MRV
D - Honeywell R7999 ControLinks

POSITION SWITCH
A - No position switch
B - Omron low position switch
C - Omron hi/lo position switch
D - T'mechanics low position switch
E - T'mechanics WP hi/lo pos switch

FILTER/SILENCER - packaged burners only
N - No filter or silencer
S - Filter/silencer assembly (silencer assembly only for OPLE 70)
F - Filter assembly (for OPLE 70 only)

COMPANION FLANGE - EB100 only
N - No flange needed
Y - Yes flange needed

SPECIFICATIONS OF OVENPAK® LE BURNERS

OVENPAK® LE 5 burner

Typical burner data		
Fuel: natural gas at 60°F with 1000 Btu/ft ³ HHV - sg = 0.6 [1]		
Combustion air: 60°F - 21% O ₂ - 50% rel. humidity - sg = 1.0 [1]		
Stated pressures are indicative. Actual pressures are a function of air humidity, altitude, type of fuel, and gas quality.		
Maximum capacity [2]	Btu/h	500,000
Minimum capacity [3]		22,000
Maximum turndown		22:1
High fire gas pressure differential [4]	"wc	2.5
Combustion air pressure differential		2.5
Combustion air volume [6]	cfm	146
Fan motorpower	hp	0.25
Pilot capacity [5]	Btu/h	15,000
Approximate inlet gas pressure required	"wc	3.5

OVENPAK® LE 10 burner

Typical burner data		
Fuel: natural gas at 60°F with 1000 Btu/ft ³ HHV - sg = 0.6 [1]		
Combustion air: 60°F - 21% O ₂ - 50% rel. humidity - sg = 1.0 [1]		
Stated pressures are indicative. Actual pressures are a function of air humidity, altitude, type of fuel, and gas quality.		
Maximum capacity [2]	Btu/h	1,000,000
Minimum capacity [3]		30,000
Maximum turndown		33:1
High fire gas pressure differential [4]	"wc	8.1
Combustion air pressure differential		8.1
Combustion air volume [6]	cfm	263
Fan motorpower	hp	1
Pilot capacity [5]	Btu/h	20,000
Approximate inlet gas pressure required	"wc	10.5

[1] sg (specific gravity) = relative density to air (density air = 0.0763 lb/ft³(st))

[2] Capacity displayed assumes blower operation on 60Hz electrical supply. Gross output will be reduced by 17% if operated on 50Hz. Fuel and air pressures should be reduced by 30% while motorpower will reduce 40% with 50Hz operation.

[3] Minimum capacity may be affected by fuel and application parameters.

[4] Gas pressure displayed for natural gas or propane. Propane pressures shown require use of optional propane nozzle.

[5] Pilot gas pressure at adjustable gas orifice should be 4-8" wc .

[6] Combustion air defined at standard temperature and pressure.

OVENPAK® LE 13 burner

Typical burner data		
Fuel: natural gas at 60°F with 1000 Btu/ft ³ HHV - sg = 0.6 [1]		
Combustion air: 60°F - 21% O ₂ - 50% rel. humidity - sg = 1.0 [1]		
Stated pressures are indicative. Actual pressures are a function of air humidity, altitude, type of fuel, and gas quality.		
Maximum capacity [2]	Btu/h	1,350,000
Minimum capacity [3]		27,000
Maximum turndown		50:1
High fire gas pressure differential [4]	"wc	6
Combustion air pressure differential		6
Combustion air volume [6]	cfm	293
Fan motorpower	hp	0.5
Pilot capacity [5]	Btu/h	27,000
Approximate inlet gas pressure required	"wc	7.6

OVENPAK® LE 15 burner

Typical burner data		
Fuel: natural gas at 60°F with 1000 Btu/ft ³ HHV - sg = 0.6 [1]		
Combustion air: 60°F - 21% O ₂ - 50% rel. humidity - sg = 1.0 [1]		
Stated pressures are indicative. Actual pressures are a function of air humidity, altitude, type of fuel, and gas quality.		
Maximum capacity [2]	Btu/h	1,600,000
Minimum capacity [3]		32,000
Maximum turndown		50:1
High fire gas pressure differential [4]	"wc	8.5
Combustion air pressure differential		8.5
Combustion air volume [6]	cfm	347
Fan motorpower	hp	1.5
Pilot capacity [5]	Btu/h	32,000
Approximate inlet gas pressure required	"wc	10.6

OVENPAK® LE 25 burner

Typical burner data		
Fuel: natural gas at 60°F with 1000 Btu/ft ³ HHV - sg = 0.6 [1]		
Combustion air: 60°F - 21% O ₂ - 50% rel. humidity - sg = 1.0 [1]		
Stated pressures are indicative. Actual pressures are a function of air humidity, altitude, type of fuel, and gas quality.		
Maximum capacity [2]	Btu/h	2,500,000
Minimum capacity [3]		50,000
Maximum turndown		50:1
High fire gas pressure differential [4]	"wc	8.4
Combustion air pressure differential		8.4
Combustion air volume [6]	cfm	570
Fan motorpower	hp	2
Pilot capacity [5]	Btu/h	50,000
Approximate inlet gas pressure required	"wc	14.0

[1] sg (specific gravity) = relative density to air (density air = 0.0763 lb/ft³(st))

[2] Capacity displayed assumes blower operation on 60Hz electrical supply. Gross output will be reduced by 17% if operated on 50Hz. Fuel and air pressures should be reduced by 30% while motorpower will reduce 40% with 50Hz operation.

[3] Minimum capacity may be affected by fuel and application parameters.

[4] Gas pressure displayed for natural gas or propane. Propane pressures shown require use of optional propane nozzle.

[5] Pilot gas pressure at adjustable gas orifice should be 4-8" wc .

[6] Combustion air defined at standard temperature and pressure.

OVENPAK® LE 30 burner

Typical burner data		
Fuel: natural gas at 60°F with 1000 Btu/ft ³ HHV - sg = 0.6 [1]		
Combustion air: 60°F - 21% O ₂ - 50% rel. humidity - sg = 1.0 [1]		
Stated pressures are indicative. Actual pressures are a function of air humidity, altitude, type of fuel, and gas quality.		
Maximum capacity [2]	Btu/h	3,150,000
Minimum capacity [3]		63,000
Maximum turndown		50:1
High fire gas pressure differential [4]	"wc	8.8
Combustion air pressure differential		8.8
Combustion air volume [6]	cfm	728
Fan motorpower	hp	3
Pilot capacity [5]	Btu/h	63,000
Approximate inlet gas pressure required	"wc	10.4

OVENPAK® LE 35 burner

Typical burner data		
Fuel: natural gas at 60°F with 1000 Btu/ft ³ HHV - sg = 0.6 [1]		
Combustion air: 60°F - 21% O ₂ - 50% rel. humidity - sg = 1.0 [1]		
Stated pressures are indicative. Actual pressures are a function of air humidity, altitude, type of fuel, and gas quality.		
Maximum capacity [2]	Btu/h	3,500,000
Minimum capacity [3]		70,000
Maximum turndown		50:1
High fire gas pressure differential [4]	"wc	10.5
Combustion air pressure differential		10.5
Combustion air volume [6]	cfm	809
Fan motorpower	hp	3
Pilot capacity [5]	Btu/h	70,000
Approximate inlet gas pressure required	"wc	13.0

OVENPAK® LE 40 burner

Typical burner data		
Fuel: natural gas at 60°F with 1000 Btu/ft ³ HHV - sg = 0.6 [1]		
Combustion air: 60°F - 21% O ₂ - 50% rel. humidity - sg = 1.0 [1]		
Stated pressures are indicative. Actual pressures are a function of air humidity, altitude, type of fuel, and gas quality.		
Maximum capacity [2]	Btu/h	4,000,000
Minimum capacity [3]		80,000
Maximum turndown		50:1
High fire gas pressure differential [4]	"wc	7
Combustion air pressure differential		7
Combustion air volume [6]	cfm	892
Fan motorpower	hp	3
Pilot capacity [5]	Btu/h	80,000
Approximate inlet gas pressure required	"wc	10.0

[1] sg (specific gravity) = relative density to air (density air = 0.0763 lb/ft³(st))

[2] Capacity displayed assumes blower operation on 60Hz electrical supply. Gross output will be reduced by 17% if operated on 50Hz. Fuel and air pressures should be reduced by 30% while motorpower will reduce 40% with 50Hz operation.

[3] Minimum capacity may be affected by fuel and application parameters.

[4] Gas pressure displayed for natural gas or propane. Propane pressures shown require use of optional propane nozzle.

[5] Pilot gas pressure at adjustable gas orifice should be 4-8" wc .

[6] Combustion air defined at standard temperature and pressure.

OVENPAK® LE 45 burner

Typical burner data		
Fuel: natural gas at 60°F with 1000 Btu/ft ³ HHV - sg = 0.6 [1]		
Combustion air: 60°F - 21% O ₂ - 50% rel. humidity - sg = 1.0 [1]		
Stated pressures are indicative. Actual pressures are a function of air humidity, altitude, type of fuel, and gas quality.		
Maximum capacity [2]	Btu/h	4,480,000
Minimum capacity [3]		90,000
Maximum turndown		50:1
High fire gas pressure differential [4]	"wc	9.2
Combustion air pressure differential		9.2
Combustion air volume [6]	cfm	1004
Fan motorpower	hp	5
Pilot capacity [5]	Btu/h	90,000
Approximate inlet gas pressure required	"wc	15.0

OVENPAK® LE 70 burner

Typical burner data		
Fuel: natural gas at 60°F with 1000 Btu/ft ³ HHV - sg = 0.6 [1]		
Combustion air: 60°F - 21% O ₂ - 50% rel. humidity - sg = 1.0 [1]		
Stated pressures are indicative. Actual pressures are a function of air humidity, altitude, type of fuel, and gas quality.		
Maximum capacity [2]	Btu/h	7,000,000
Minimum capacity [3]		200,000
Maximum turndown		35:1
High fire gas pressure differential [4]	"wc	12
Combustion air pressure differential		12
Combustion air volume [6]	cfm	1617
Fan motorpower	hp	7.5
Pilot capacity [5]	Btu/h	90,000
Approximate inlet gas pressure required	"wc	13

[1] sg (specific gravity) = relative density to air (density air = 0.0763 lb/ft³(st))

[2] Capacity displayed assumes blower operation on 60Hz electrical supply. Gross output will be reduced by 17% if operated on 50Hz. Fuel and air pressures should be reduced by 30% while motorpower will reduce 40% with 50Hz operation.

[3] Minimum capacity may be affected by fuel and application parameters.

[4] Gas pressure displayed for natural gas or propane. Propane pressures shown require use of optional propane nozzle.

[5] Pilot gas pressure at adjustable gas orifice should be 4-8" wc .

[6] Combustion air defined at standard temperature and pressure.

OVENPAK® LE EB40, EB65 & EB100 burners

Typical burner data				
Fuel: natural gas at 60°F with 1000 Btu/ft ³ HHV - sg = 0.6 [1]				
Combustion air: 60°F - 21% O ₂ - 50% rel. humidity - sg = 1.0 [1]				
Stated pressures are indicative. Actual pressures are a function of air humidity, altitude, type of fuel, and gas quality.				
		EB40	EB65	EB100
Chamber pressure	"wc	-0.5	-0.5	-0.5
Maximum capacity	Btu/h	4,000,000	6,500,000	10,000,000
Minimum capacity [2]		40,000	40,000	400,000
Maximum turndown		100:1	100:1	25:1
High fire gas pressure differential [3]	"wc	22.5	19.5	21
Combustion air pressure differential [6]		22.5	19.5	21
Combustion air volume [4]	cfm	950	1,545	2290
Pilot capacity [5]	Btu/h	65,000	65,000	90,000
Inlet air pressure differential [7]	"wc	27.0	21.0	25
Approximate inlet gas pressure required [8]	"wc	38	27	25

[1] sg (specific gravity) = relative density to air (density air =0.0763 lb/ft³(st))

[2] Minimum capacity may be affected by fuel and application parameters.

[3] Gas pressure displayed for natural gas or propane. Propane pressures shown require use of optional propane nozzle.

[4] Combustion air defined as standard temperature and pressure.

[5] Pilot gas pressure at adjustable gas orifice should be 4-8" wc .

[6] Combustion air differential pressure to be measured between burner test connection and combustion chamber

[7] Inlet combustion air differential pressure to be measured between burner inlet and combustion chamber

[8] For EB versions, valid only for the case where the burner has internal controls

MATERIALS OF CONSTRUCTION

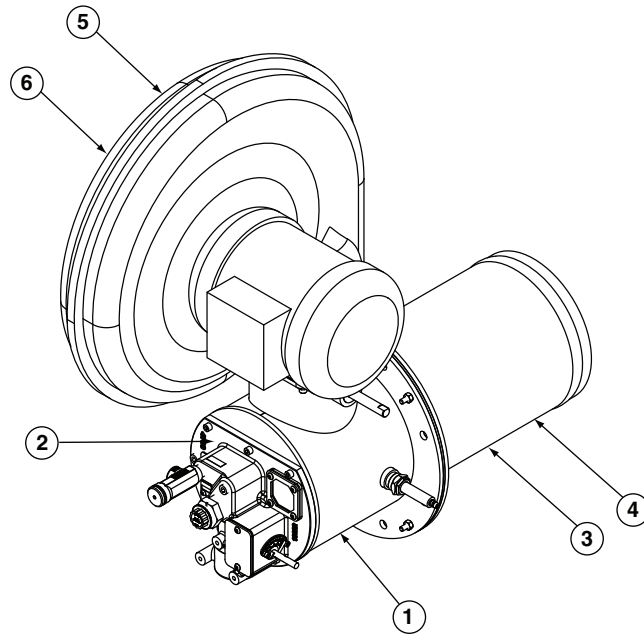

Item number	Burner part	Material
1	Housing	1010 steel (1.1121)
2	Back plate	Cast iron
3	Mixing cone (inside discharge sleeve)	310 Stainless steel (1.4841)
4	Nozzle (inside discharge sleeve)	Cast iron
5	Impeller (inside fan case)	Aluminum
6	Fan case	Aluminum / steel

SELECTION CRITERIA

OVENPAK® LE burner versions

The OVENPAK® LE burner is a nozzle mixing burner for use on a wide variety of industrial applications. The burner utilizes advanced, rapid mixing to produce low levels of NOx and CO while maintaining high turndown and operational flexibility.

The OVENPAK® LE burner is available in several versions. Packaged burners contain an integral combustion air blower and internally linked control valves to maintain the gas-air ratio over the full operating range. EB (external blower) burners are equipped with an air inlet adapter and are designed for remote blower applications. EB versions include independent internal fuel and air valves designed to be connected externally to a parallel positioning fuel-air ratio control system. The EB version may also be ordered with no internal fuel and air valves.

The OVENPAK® LE burner includes a combustion air blower with non-sparking paddle wheel-type impeller, pilot, spark ignitor, stainless steel discharge sleeve, mixing cone and provision for a flame safeguard sensor.

OVENPAK® LE burners feature a unique balanced pressure design with equal fuel pressures and air pressures. This feature provides easy set-up and verification. In addition, balanced supply pressures provide resistance to fluctuations or upsets in the firing chamber pressure. During upsets, the burner's ratio will be maintained for stability and emissions control.

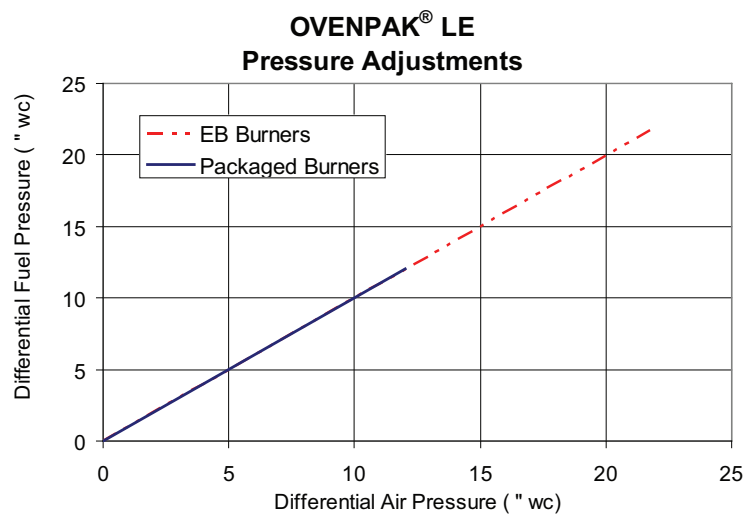

Application details

MAXON OVENPAK® LE burner can be used in all direct fired air heating applications. It combines flexibility and stability with high turndown and low NOx/CO emissions. It can be used in all air heating applications that require low NOx firing and allow excess combustion air. Consult installation instructions under "Burner mounting" for mounting and insulating requirements.

OVENPAK® LE burners can be fired into tubes up to 8500 Btu/h/in² of tube cross sectional area. The OVENPAK® LE may also be used for indirect applications up to 1500° F.

Maximum capacities

All OVENPAK® LE burners can be fired at higher than maximum capacities if sufficient combustion air and fuel gas is provided to the burner. EB burners may be overfired up to 15% over cataloged capacities with an adequate combustion air blower. Burner emissions will be affected by overfiring. Fuel pressure will increase in kind to maintain balance pressure design on EB burners.

Process back pressure

Standard packaged OVENPAK® LE burners with integrated fan can accept static chamber pressures between -5" wc and +5" wc. The unique balanced pressure design provides resistance to unstable application pressures. During system upsets, the burner's output capacity will be impacted but the air-fuel ratio and stability will be maintained. The capacity of packaged burners will be affected by chamber pressure.

EB burners with external valves retain the balanced pressure design at the burner nozzles. Process pressures for EB burners should be limited to +5 psi to -5 psi. Care should be taken when selecting external air and fuel valves to closely match the pressure drops at full flow.

Blower orientation

Blower should be positioned only with the motor parallel to the burner-oven flange. Altering blower position is not recommended as turndown and emissions will be affected. See illustrations under heading "Dimensions and weights" for proper orientation.

Pipe train

For proper air-to-fuel ratio, do not exceed 4" wc pressure drop between the burner inlet and the regulator. Higher pressure drops will impact turndown and emissions.

Process temperature

The construction of the burner allows operation in all applications with process temperatures from ambient up to 1000° F.

Piloting & ignition

All OVENPAK® LE burners are equipped with a self-piloted design. Pilots shall be used only for ignition of the main flame (interrupted). Use of a standing (continuous) pilot will reduce burner turndown and negatively impact emissions. Use minimally 5000 V/200 VA ignition transformers for sparking of the spark ignitor. Optional ignition equipment for hazardous locations is available as well as high energy ignitors for direct ignition.

Start the burner at low fire settings only. Direct spark ignition of standard OVENPAK® LE burners is possible. Ignitor should spark to the cone only. Arc should be easily visible through the observation window for verification of ignition and maintenance.

Locate one pilot gas valve as close as possible to the pilot burner gas inlet to have fast ignition of the pilot burner.

Ratio control

Burner should be modulated between low and high fire position settings only. Overtraveling can damage internal linkage. Low and high fire stops are intended as visual indicators only. They should not be used as the low or as the high fire hard stops.

Packaged burners with internal linkage should have no more than 4" wc pressure drop in the fuel train from the regulator to burner inlet.

OVENPAK® LE burners may operate with excess air levels of 5-40%. Best NOx emissions will be produced with 35-40% excess air. CO emissions will be influenced by ratio and a variety of other factors. See "Expected emissions" for more information.

Typical ignition sequence

- Pre-purge of burner and installation, according to the applicable codes and the installation's requirements.
- Combustion air control valve shall be in the minimum position to allow minimum combustion air flow to the burner.
- Pre-ignition (typically 2 seconds sparking in air).
- Open pilot gas and continue to spark the ignitor (typically 5 seconds).
- Stop sparking, continue to power the pilot gas valves and start flame check. Trip burner if no flame from here on.
- Check pilot flame stability (typical 5 seconds to prove stable pilot).
- Open main gas valves and allow enough time to have main gas in the burner (typical 5 seconds + time required to have main gas in the burner).
- Close the pilot gas valves.
- Release to modulation (allow modulation of the burner).

Above sequence shall be completed to include all required safety checks during the start-up of the burner (process & burner safeties).

Flame supervision

OVENPAK® LE flames shall be supervised by flame scanners or flame rods allowing verification of both pilot flame and main flame. (It is not possible to distinguish main and pilot flame.)

Scanners are mounted on the burner back plate and look through the fuel nozzle.

Pay attention to possible pick-up of strange flames (if any in the furnace).

Flame development

The OVENPAK® LE creates stout, thoroughly mixed flames with short lengths. Burner flames remain consistent across most burner sizes.

Dimensions in inches unless stated otherwise		
Burner size	Flame diameter	Flame length [1]
5	5	7
10	5	7.5
13	9	20
15		
25		
30	11	24
35		
40		
45		
70	11	18
EB40	9	20
EB65	11	24
EB100	11	24

[1] Flame length indicated is measured from the end of the discharge sleeve.

Cross velocities

Cross velocities up to 3000 ft/min can be allowed over the OVENPAK® LE flame. Contact MAXON for assistance for cross velocity over the flame in excess of 3000 ft/min, or for processes with high moisture content.

Combustion air control & piping

OVENPAK® LE EB burners require combustion air control valves with high turndown (to guarantee correct air flow at minimum capacity). Air control valves shall be properly sized. Typically, the air control valve diameter shall be smaller than the burner air inlet. Combustion air piping to the burner shall be done in such a way that the air flow to the burner will not disturb the flame. One diameter straight pipe length is recommended at the blower air inlet. Location of air control valves directly on the burner inlet is not possible.

Packaged burners and fans will be shipped disassembled. Blower orientation other than depicted under “Dimensions and weights” is not recommended.

Fuels

Standard OVENPAK® LE burners are designed for low NOx firing of natural gas only. Optional versions are available to fire propane/LPG. When firing propane, butane or other alternate fuels, higher NOx will be produced. Contact MAXON for expected influence on emissions.

Expected emissions

Packaged burner emissions can be controlled by adjusting the regulator at high fire position, and by adjusting the tuning screw at lower firing position. The fine tuning screw is located below the metal access plate under the viewport at the backplate of each burner. This screw is only intended to allow fine tuning of the NOx and CO production at midfire. No more than 2 turns of the screw should be utilized in either direction. EB burners do not include an internal air and gas linkage or a tuning screw.

Typical NOx for OVENPAK® LE burners firing natural gas with 40% excess air is approximately 1/2 to 1/3 the NOx of conventional burners.

CO highly depends on the installation's lay-out and can be reduced if sufficient dwell time after the flame is allowed. CO can generally be controlled below most known standards and regulatory requirements. Consult MAXON for correct application information.

Exact emissions performance may vary in your application. Contact MAXON for information on installation-specific estimates and guaranteed values. No guarantee of emissions is intended or implied without specific, written guarantee from MAXON.

Discharge sleeves

Discharge sleeve should be selected based on the process conditions. Several materials and length configurations are available.

Discharge sleeves	Discharge sleeve material	Application conditions
Standard	309 / 310 SS (1.4828 / 1.4841)	<700° F direct fired
High temperature sleeve (optional)	253 MA (1.4333)	700° F-1000° F direct fired
Short sleeve (optional)	310 SS (1.4841)	<1000° F indirect fired
Refractory lined sleeve (optional)	310 SS (1.4841) & castable refractory	up to 1500°F indirect fired

DIMENSIONS AND WEIGHTS

OVENPAK® LE packaged burner sizes 5 through 25

- 1) Air test port 1/4" NPT
- 2) Gas test port 1/4" NPT
- 3) Flame rod or flame scanner (optional)
- 4) Spark ignitor
- 5) Spark ignitor removal
- 6) Air pressure switch test port 1/8" NPT
- 7) Pilot gas inlet 3/8" NPT
- 8) Gas inlet
- 9) Removal of optional flame rod
- 10) Tuning screw

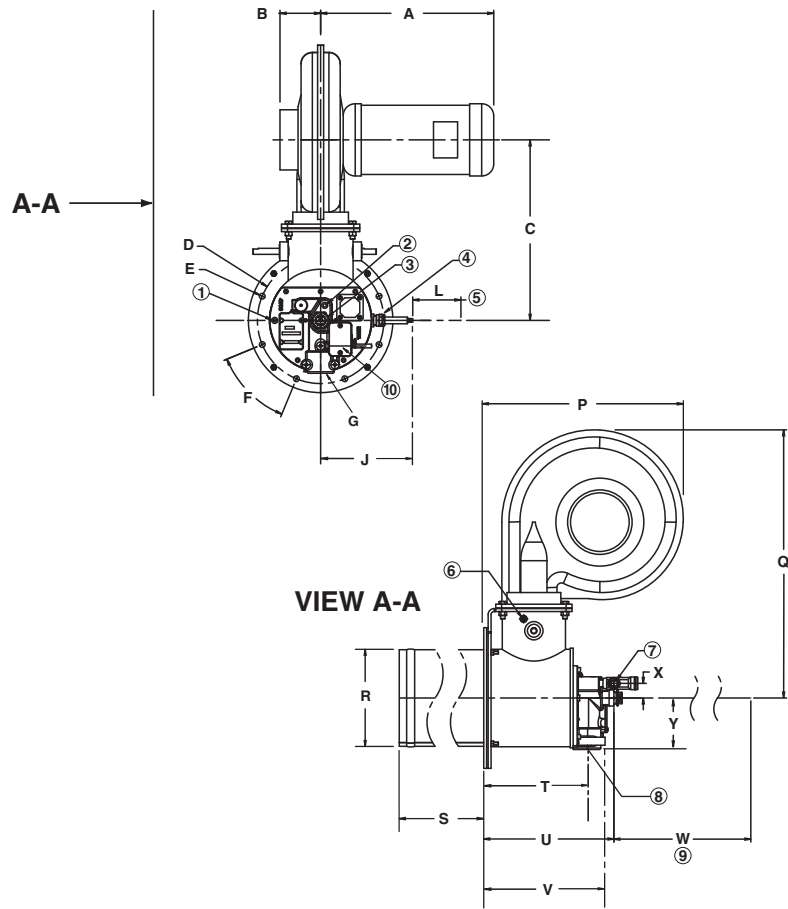

Dimensions in inches unless stated otherwise										
Model	A	B	C	D	E	F	G	J	L	P
5	12.50	3.63	16.56	10.5	0.475	45°	1-1/4" NPT	7.65	4.0	20.67
10	12.50	3.63	16.56	10.5	0.475	45°	1-1/4" NPT	7.65	4.0	20.67
13	14.38	3.38	15.00	10.5	0.475	45°	1-1/4" NPT	7.65	4.0	17.01
15	14.1	3.38	16.56	10.5	0.475	45°	1-1/4" NPT	7.65	4.0	20.67
25	12.50	3.63	16.56	10.5	0.475	45°	1-1/4" NPT	7.65	4.0	20.67

Dimensions in inches unless stated otherwise													
Model	Q	R	R Ref. lined	S Std.	S Short	S Ref. lined	T	U	V	W	X	Y	Weight lbs
5	26.70	6.30	12.12	12.0	4.38	7.875	8.94	11.10	10.34	18.5	1.250	4.39	101
10					4.63								
13	8.30	4.63											
15													
25	26.70	8.30	4.63										

OVENPAK® LE packaged burner sizes 30 through 45

- 1) Air test port 1/4" NPT
- 2) Gas test port 1/4" NPT
- 3) Flame rod or flame scanner (optional)
- 4) Spark ignitor
- 5) Spark ignitor removal
- 6) Air pressure switch test port 1/8" NPT
- 7) Pilot gas inlet 3/8" NPT
- 8) Gas inlet
- 9) Removal of optional flame rod
- 10) Tuning screw

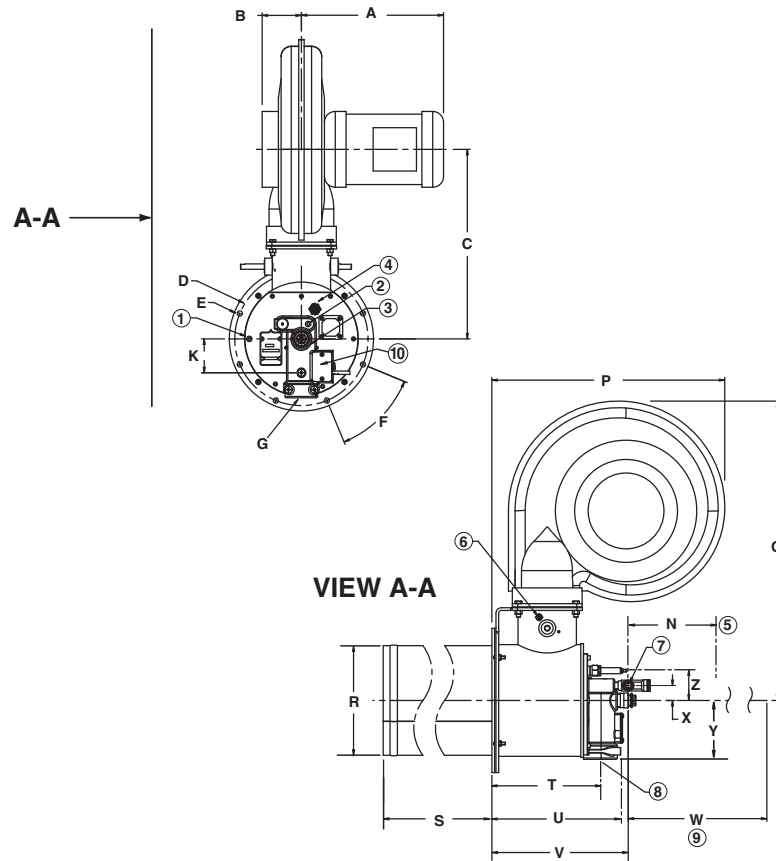

Dimensions in inches unless stated otherwise										
Model	A	B	C	D	E	F	G	P	Q	R
30	13.13	3.63	17.50	12.312	0.475	45°	2" NPT	21.51	27.64	10.24
35	14.63	3.75	17.75	12.312	0.475	45°	2" NPT	21.51	27.86	10.24
40	14.63	3.75	17.75	12.312	0.475	45°	2" NPT	21.51	27.86	10.24
45	16.00	4.25	18.69	12.312	0.475	45°	2" NPT	23.42	29.06	10.24

Dimensions in inches unless stated otherwise											
Model	S Std.	S Short	S Ref. lined	T	U	V	W	X	Y	Z	Weight lbs
30	16.0	8.75	7.875	10.08	11.90	12.59	24.5	1.38	5.44	2.75	180
35				10.08	11.90	12.59	24.5	1.38	5.44	2.75	
40				10.08	11.90	12.59	24.5	1.38	5.44	2.75	
45				10.08	11.90	12.59	24.5	1.38	5.44	2.75	

OVENPAK® LE packaged burner size 70

- 1) Air test port 1/4" NPT
- 2) Gas test port 1/4" NPT
- 3) Flame rod or UV scanner (optional)
- 4) Spark ignitor
- 5) Pilot gas inlet 3/8" NPT
- 6) Gas inlet
- 7) 30" required for removal of optional flame rod
- 8) Tuning screw
- 9) Air pressure switch test port 1/8" NPT

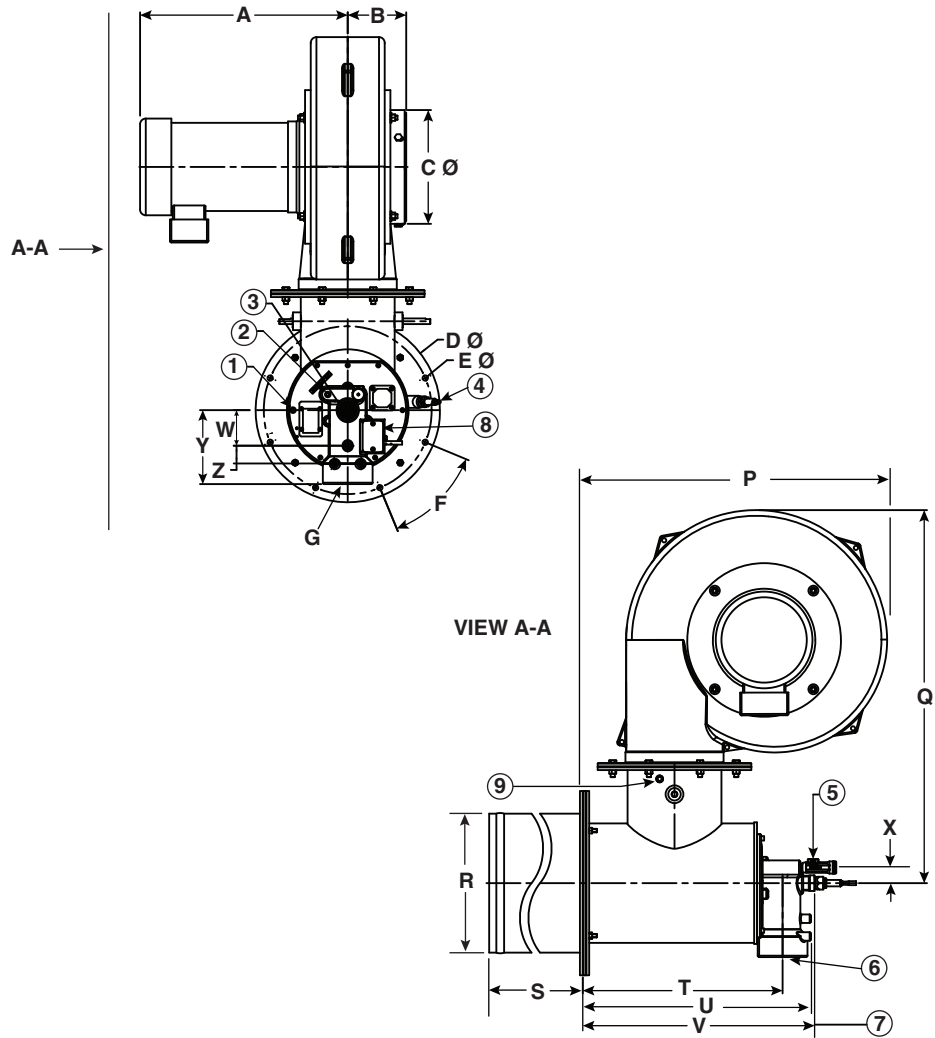

Dimensions in inches unless stated otherwise											
Model	A	B	C	D	E	F	G	P	Q	R Ø	R Ø Ref. lined
70	18.25	5.14	10.0	16.19	0.47	45°	3" NPT	26.75	32.79	12.33	16.21

Dimensions in inches unless stated otherwise											
Model	S Std.	S Short	S Ref. lined	T	U	V	W	X	Y	Z	Weight lbs
70	23.12	11.75	11.75	17.56	20.07	20.38	3.12	1.38	6.5	1.56	245

OVENPAK® LE burner size EB40

- 1) Air test port 1/4" NPT
- 2) Gas test port 1/4" NPT
- 3) Flame rod or flame scanner (optional)
- 4) Spark ignitor
- 5) Spark ignitor removal
- 6) Air pressure switch test port 1/8" NPT
- 7) Pilot gas inlet 3/8" NPT
- 8) Gas inlet
- 9) Removal of optional flame rod

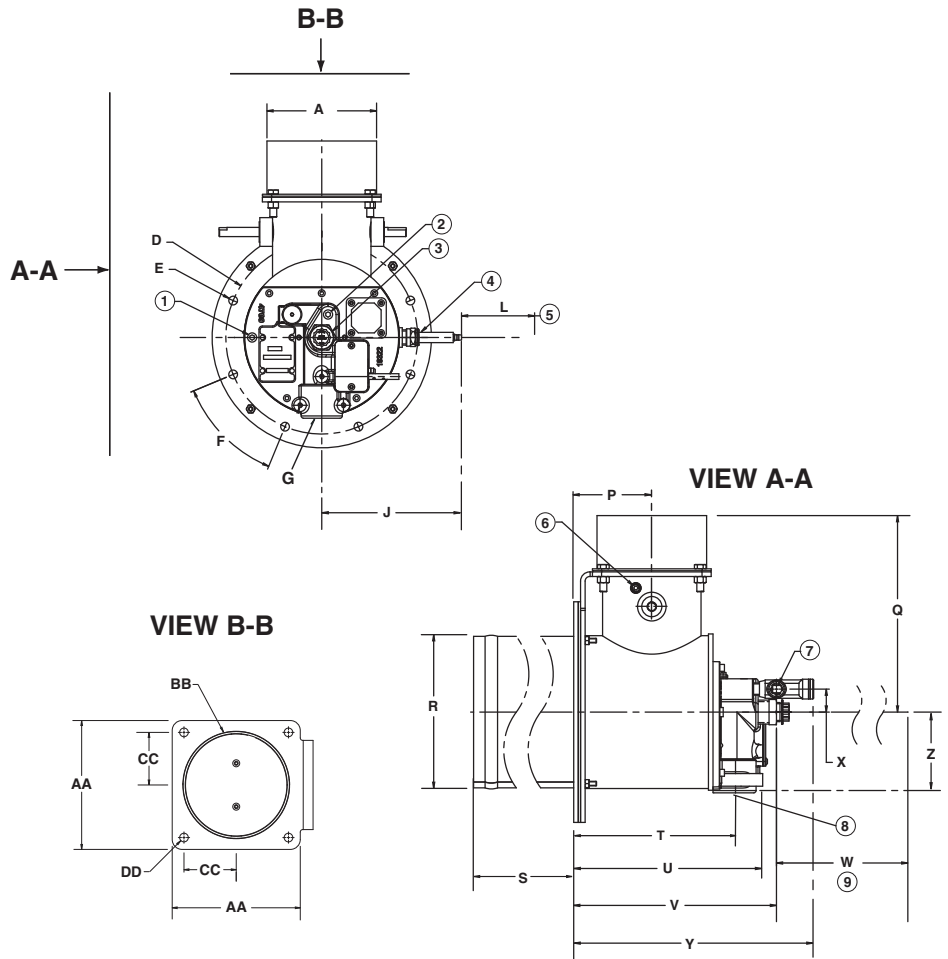

Dimensions in inches unless stated otherwise													
Model	A	D	E	F	G	J	L	P	Q	R	S Std.	S Short	S Ref. lined
EB40	6.0	10.50	0.475	45°	1-1/4" NPT	2.375	4.0	4.0	10.89	8.36	12.0	4.63	7.875

Dimensions in inches unless stated otherwise												
Model	T	U	V	W	X	Y	Z	AA	BB	CC	DD	Weight lbs
EB40	8.94	10.34	11.10	18.5	1.25	13.13	4.39	6.50	5.18	2.65	0.438	45

OVENPAK® LE burner size EB65

- 1) Air test port 1/4" NPT
- 2) Gas test port 1/4" NPT
- 3) Flame rod or flame scanner (optional)
- 4) Spark ignitor
- 5) Spark ignitor removal
- 6) Air pressure switch test port 1/8" NPT
- 7) Pilot gas inlet 3/8" NPT
- 8) Gas inlet
- 9) Removal of optional flame rod

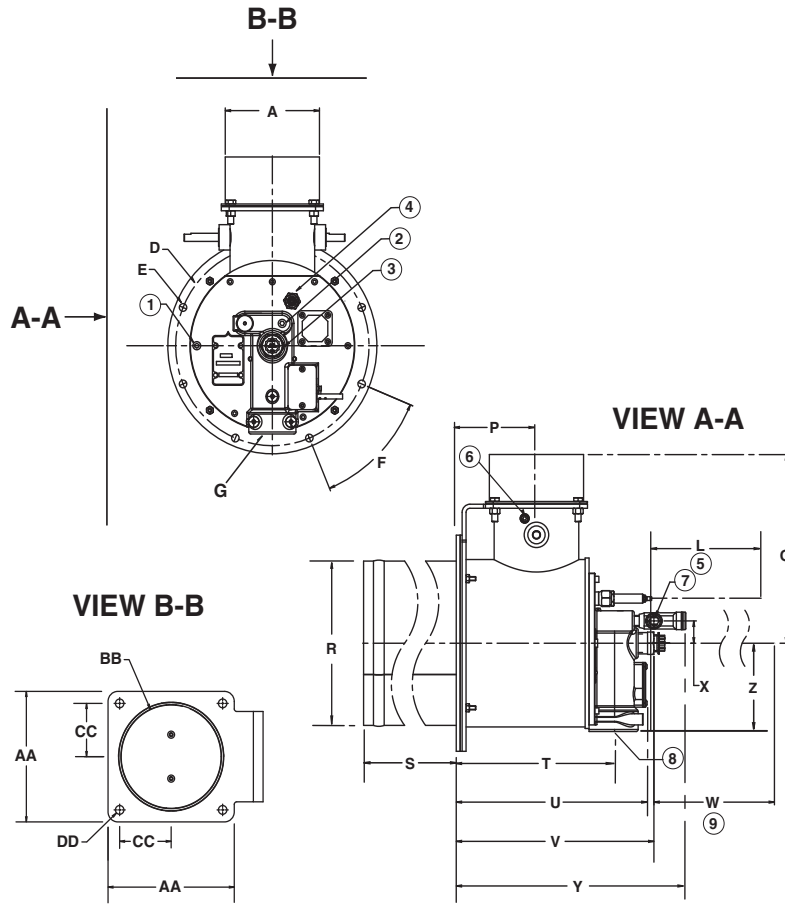

Dimensions in inches unless stated otherwise

Model	A	D	E	F	G	H	L	P	Q	R	S Std.	S Short	S Ref. lined
EB65	6.0	12.31	0.475	45°	2" NPT	2.375	7.0	5.11	11.62	10.24	16.0	8.75	7.875

Dimensions in inches unless stated otherwise

Model	T	U	V	W	X	Y	Z	AA	BB	CC	DD	Weight lbs
EB65	10.08	11.90	12.59	24.5	1.38	14.62	5.44	6.50	5.18	2.65	0.438	65

OVENPAK® LE burner size EB100

- 1) Air test port 1/4" NPT
- 2) Gas test port 1/4" NPT
- 3) Flame rod or UV scanner (optional)
- 4) Spark ignitor
- 5) Pilot gas inlet 3/8" NPT
- 6) Gas inlet 3" NPT
- 7) 30" required for removal of optional flame rod
- 8) Optional companion flange
- 9) Air pressure switch test port 1/8" NPT

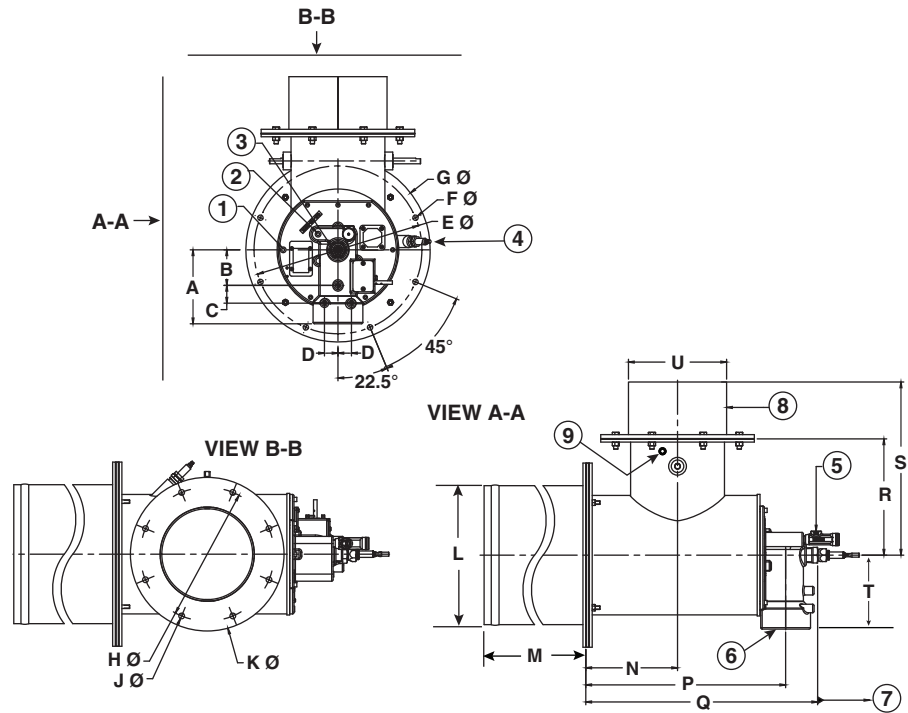

Dimensions in inches unless stated otherwise										
Model	A	B	C	D	E Ø	F Ø	G Ø	H Ø	J Ø	K Ø
EB100	6.5	3.12	1.56	1.19	14.75	0.47	16.19	11.75	.50	13.5

Dimensions in inches unless stated otherwise													
Model	L Ø	L Ø Ref. lined	M	M Short	M Ref. lined	N	P	Q	R	S	T	U Ø	W
EB100	12.33	16.21	27.75	17.75	11.75	8.06	17.56	20.38	10.22	15.22	6.5	8.62	

ACCESSORY DIMENSIONS

Spark ignitors

OPLE 5 through 25, EB40

- 1) Set spark ignitor flush with outside of mixing cone
- 2) Spark ignitor

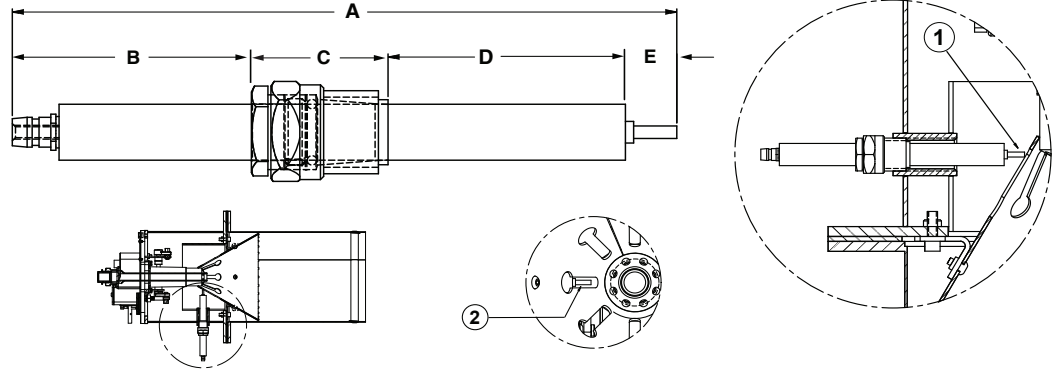

OPLE 30 through 45, EB65

- 1) Set spark ignitor electrode 1/8"-3/16" from side of slot in mixing cone
- 2) Spark ignitor to be located within mixing cone slot, and at least 1/8" from edge of slot

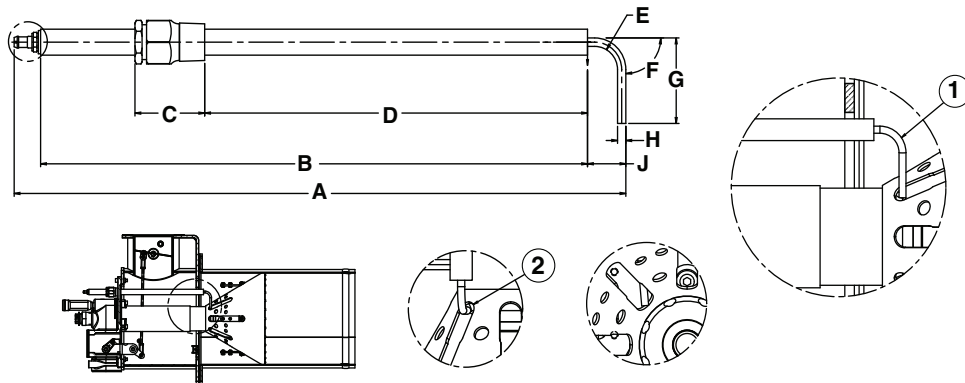

OPLE 70, EB100

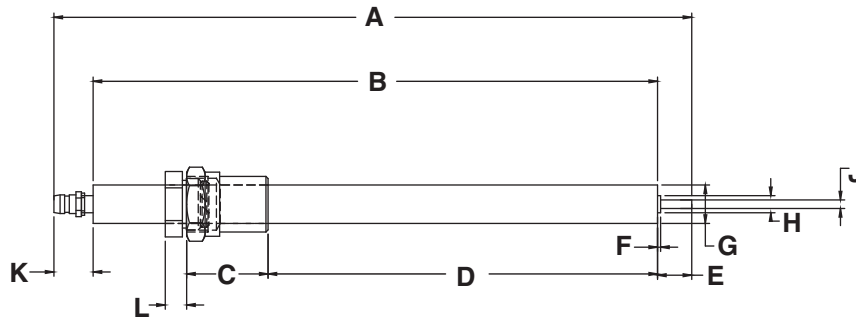

Dimensions in inches unless stated otherwise

Burner model	A	B	C	D	E	F	G Ø	H Ø	J Ø	K	L
5-25, EB40	6.47	1.9	1.34	2.65	.50	-	-	-	-	---	---
30-45, EB65	13.42	12.0	1.53	8.4	.50	90°	1.841	0.182	0.841	---	---
70, EB100	9.32	8.25	1.19	5.693	.50	.045	.562	.25	.125	.573	.312

Flame rods

OPLE 5 through 45, EB40 & EB65

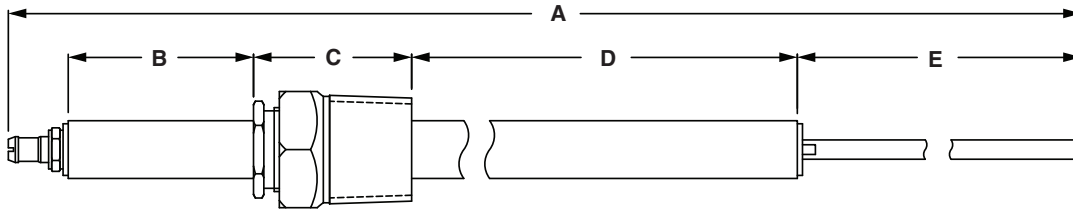

OPLE 70, EB100

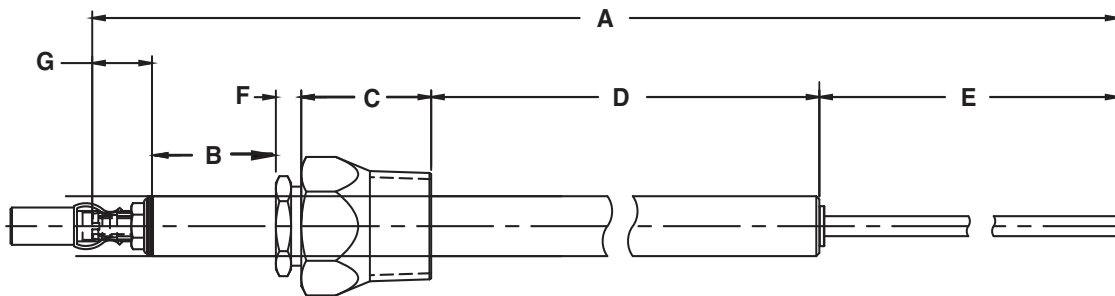

Dimensions in inches unless stated otherwise							
Burner model	A	B	C	D	E	F	G
5 - 25, EB40	21.33	1.67	1.53	8.55	9.0	---	---
30 - 45, EB65	26.46	2.6	1.53	12.75	9.0	---	---
70, EB100	32.652	1.22	1.28	20.31	9.0	.25	.59

Filter-silencer

OPLÉ 5 through 45

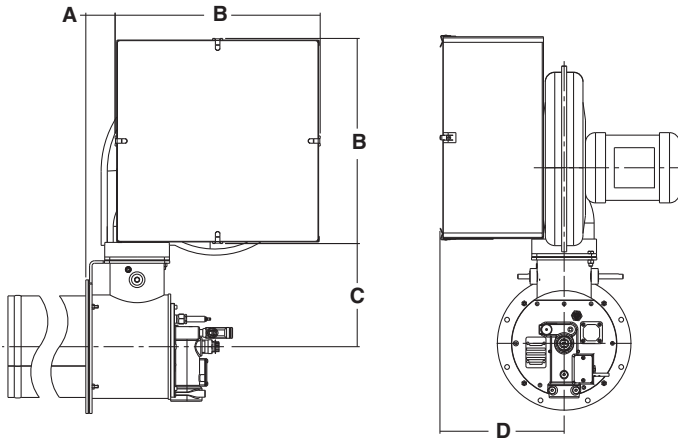

Size	dB(A)*	dB(A)* with silencer
5	80	78
10	85	81
13	85.7	81
15	86.1	82
25	87.2	84
30	89.3	82
35	89.5	82
40	89.5	82
45	88	83
70	94.2	84

* dB(A) measured at 39" to burner center

Dimensions in inches unless stated otherwise				
Burner model	A	B	C	D
5	2.09	20.44	9.34	12.38
10	2.09	20.44	9.34	12.38
13	1.18	20.44	8.59	13.92
15	2.09	20.44	9.34	12.38
25	2.09	20.44	9.34	12.38
30	2.92	20.44	10.28	12.38
35	2.17	24.44	9.40	12.67
40	2.17	24.44	9.40	12.67
45	2.95	24.44	10.59	13.57

OPLÉ 70

Filter option

Silencer option

Customer needs to supply extra support for silencer

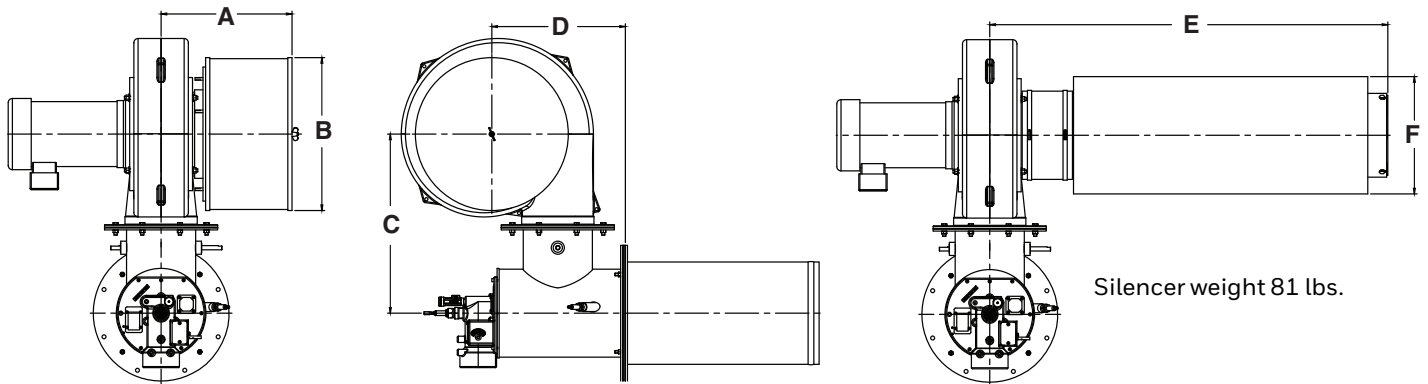

Silencer weight 81 lbs.

Dimensions in inches unless stated otherwise						
Burner model	A	B Ø	C	D	E	F Ø
70	15.62	18.25	21.38	15.94	47.52	14

Typical hi/lo position switches

- 1) Lo position switch
- 2) Hi position switch

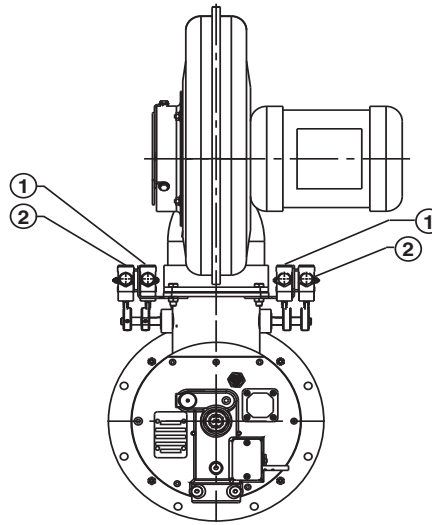

Refractory lined discharge sleeve

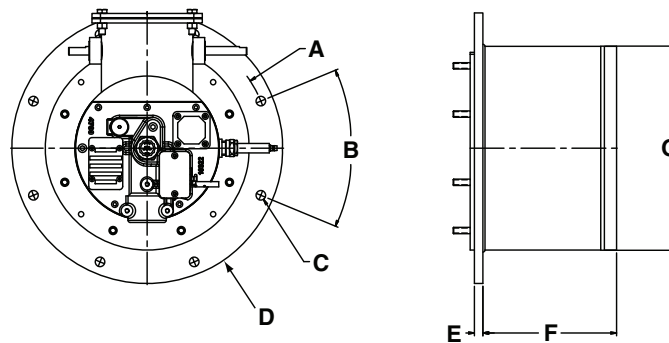

Dimensions in inches unless stated otherwise							
Burner size	A Ø	B	C Ø	D Ø	E	F	G Ø
5-10 OPLE	14.5	45°	0.562	15.937	0.375	7.875	12.12
13-25 OPLE 40 EB OPLE				18.0	0.50		
30-45 OPLE 65 EB OPLE	16.531		0.47	20.19	0.375	11.75	14.13
70 OPLE 100 EB OPLE	18.75						16.21

Note: Install refractory-lined sleeve so that metal sleeve is fully covered with insulation.

Honeywell Modutrol

1) Control motor

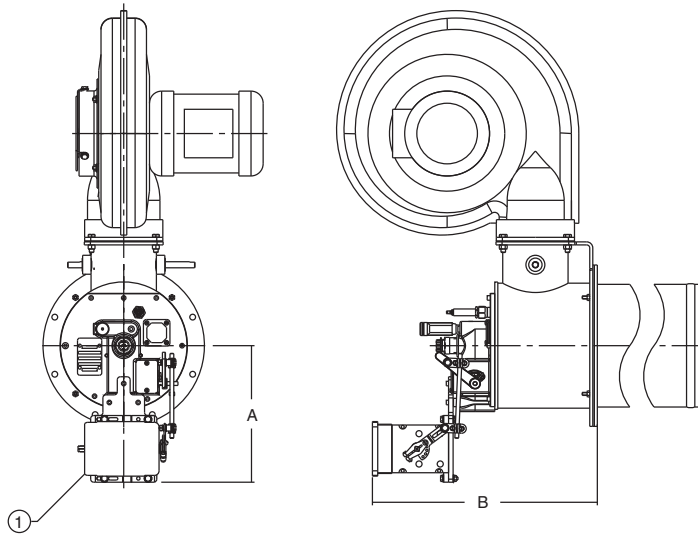

Dimensions in inches unless stated otherwise

Burner model	A	B
5-25	10.26	17.00
30-45 (shown)	11.26	18.55
70	11.26	26.72

MAXON SMARTLINK® MRV

1) 1/2" - 14 NPT

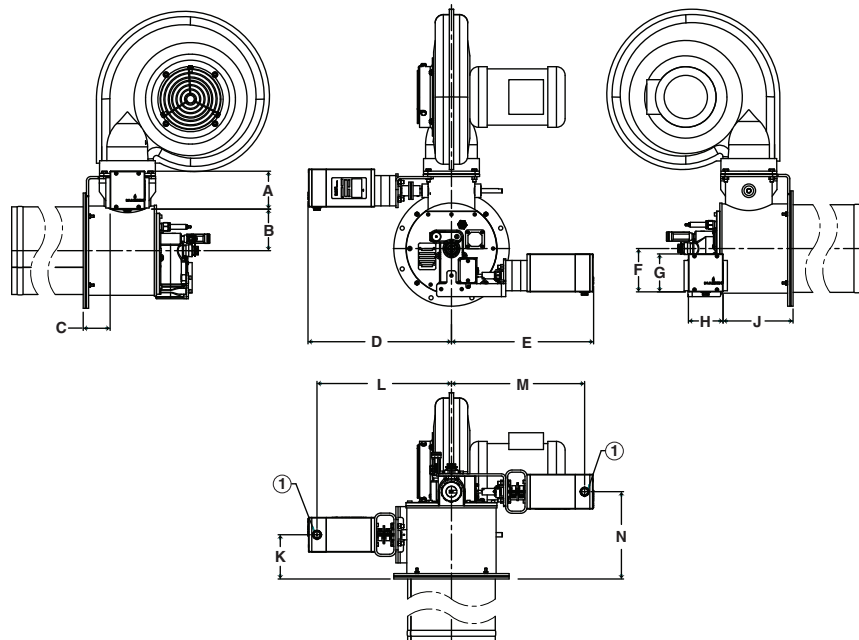

Dimensions in inches unless stated otherwise													
Burner model	A	B	C	D	E	F	G	H	J	K	L	M	N
5-25	4.38	3.86	2.28	16.57	16.42	4.38	4.0	4.0	6.94	4.28	15.53	15.38	8.94
30-45 (shown)	4.38	4.8	3.11	16.57	16.42	5.0	4.38	4.0	8.08	5.11	15.53	15.38	10.08
70	4.38	9.69	6.06	17.86	16.46	5.38	4.38	4.0	15.56	8.06	15.45	16.85	17.56

INSTALLATION AND OPERATING INSTRUCTIONS



Please read the operating and mounting instructions before using the equipment. Install the equipment in compliance with the prevailing regulations.

Bedrijfs- en montagehandleiding voor gebruik goed lezen! Apparaat moet volgens de geldende voorschriften worden geïnstalleerd.

Lire les instructions de montage et de service avant utilisation! L'appareil doit impérativement être installé selon les réglementations en vigueur.

Betriebs- und Montageanleitung vor Gebrauch lesen! Gerät muß nach den geltenden Vorschriften installiert werden.

Application requirements

View port

A view port to observe burner flame is helpful to inspect flame aspect. Locate the view port downstream of the flame, looking back to the burner block. Make sure the complete flame can be evaluated.

Required ancillary equipment

Ensure that all ancillary equipment for safe operation and correct performance of the OVENPAK® LE burner is installed, as described in the applicable local codes and/or process-related instructions. An accurate control of the air/gas ratio is essential for optimal performance of the burner.

Support burner air and gas piping

The OVENPAK® LE burner shall not be used as support for the piping to the burner. Gas and air piping shall be supported in such a way that no additional loads will be created on the burner.

Burner mounting flange loads

Check burner weight and reinforce burner mounting flange or combustion chamber/furnace back wall if necessary to take complete burner weight.

INSTALLATION INSTRUCTIONS

Storage

OVENPAK® LE burners shall be stored dry (inside).

Handling

OVENPAK® LE burners are shipped as complete units. Packaged burners may be shipped with blowers removed. Handle burners with care during unpacking, transport, lifting and installation. Use proper equipment. Any impact on the burner could result in damage.

Flange the burner to the installation

Bolt the burner to the installation's burner mounting flange. Use proper gasketing. Tighten the flange bolting with correct torque. Retighten all bolts after first firing and regularly after commissioning.

Filter assembly

Filters and blowers are shipped loose and require assembly prior to burner installation. See the sketches below for proper filter assembly instructions.

Packaged burner size OPLE 5, 10 & 13

- 1) Filter element
- 2) Filter screen
- 3) Fasteners supplied with filter assembly
- 4) Filter housing
- 5) Inlet guard supplied with blower
- 6) Fasteners supplied with filter assembly
- 7) Filter adapter
- 8) Fasteners supplied with blower
- 9) Blower

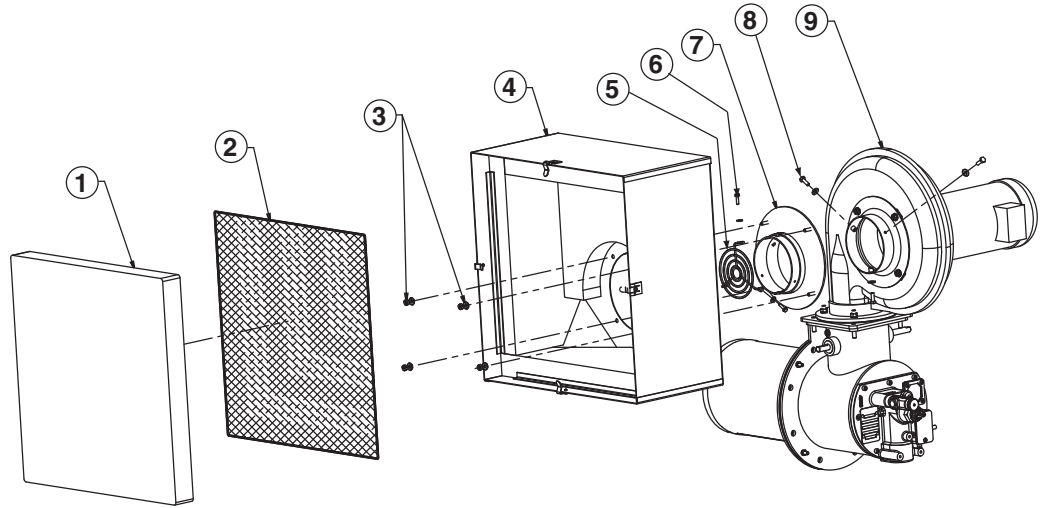

Packaged burner sizes OPLE 15, 25 & 30

- 1) Filter element
- 2) Filter screen
- 3) Inlet guard and fasteners supplied with blower
- 4) Filter housing
- 5) Blower

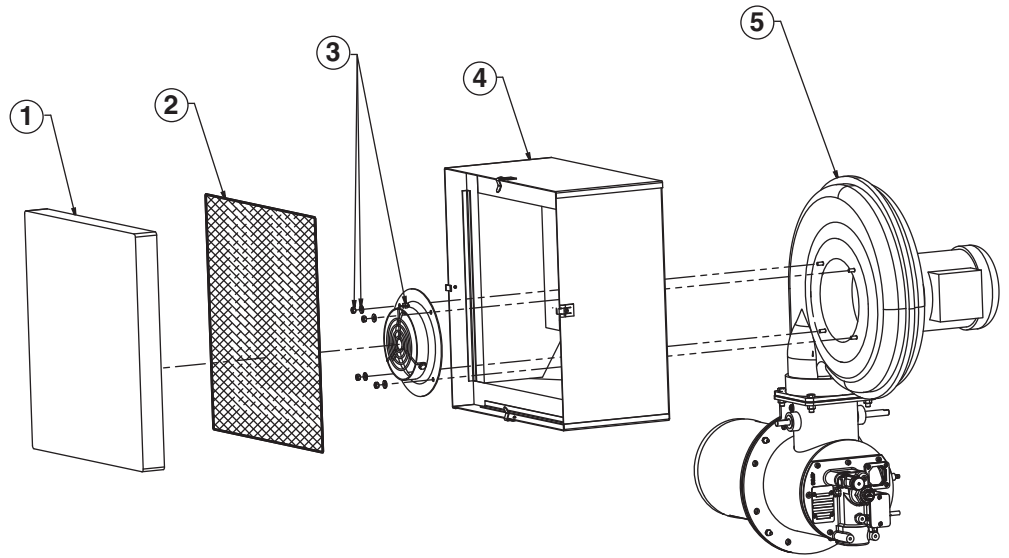

Packaged burner sizes OPLE 35 & 40

- 1) Filter element
- 2) Filter screen
- 3) Fasteners supplied with filter assembly
- 4) Filter housing
- 5) Inlet guard supplied with blower
- 6) Fasteners supplied with filter assembly
- 7) Filter adapter
- 8) Blower
- 9) Fasteners supplied with blower

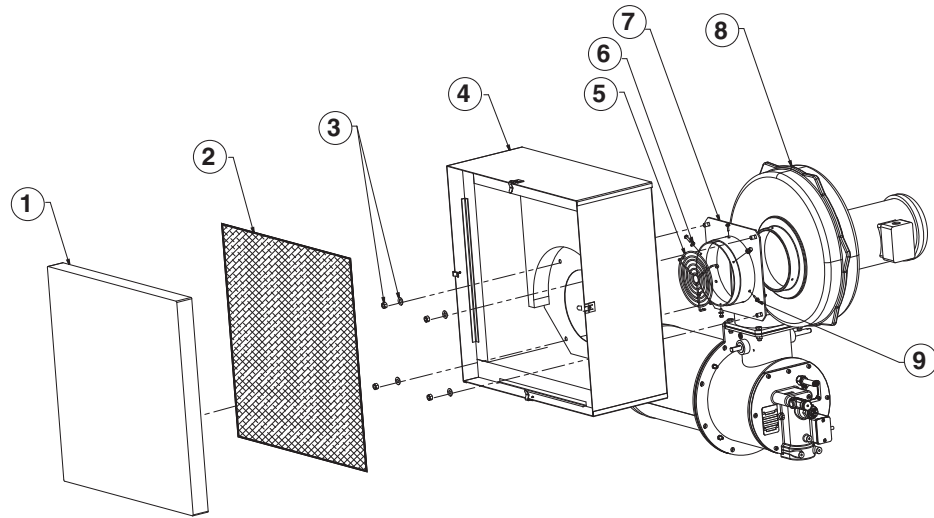

Packaged burner size OPLE 45

- 1) Filter element
- 2) Filter screen
- 3) Nuts supplied with blower
- 4) Filter housing
- 5) Blower

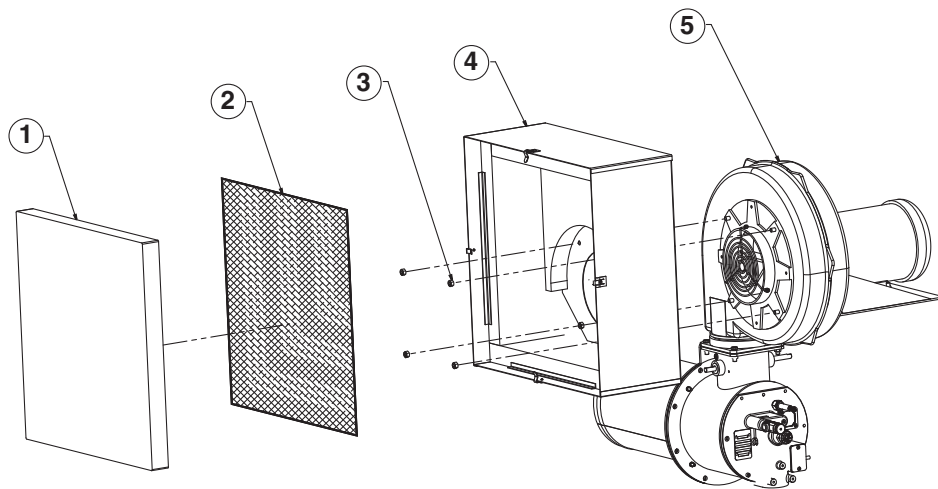

Packaged burner size OPLE 70

- 1) Filter
- 2) Adapter flange
- 3) Hardware (provided)

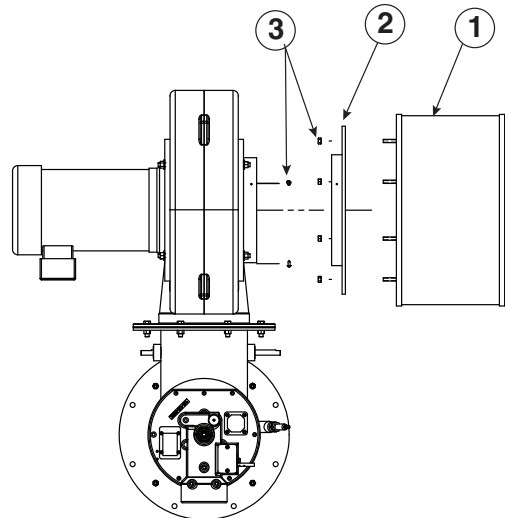

Burner mounting

OPLÉ 5, OPLÉ 10

- 1) Heater shell
- 2) Insulated wall (6" maximum depth)
- 3) Cut opening 1" larger than sleeve diameter
- 4) This area may be packed with insulation up to 2" in depth
- 5) Burner flange
- 6) Gasket supplied with burner
- 7) Discharge sleeve-flange
- 8) Optional gasket
- 9) Heater wall
- 10) Cone Adapter plate

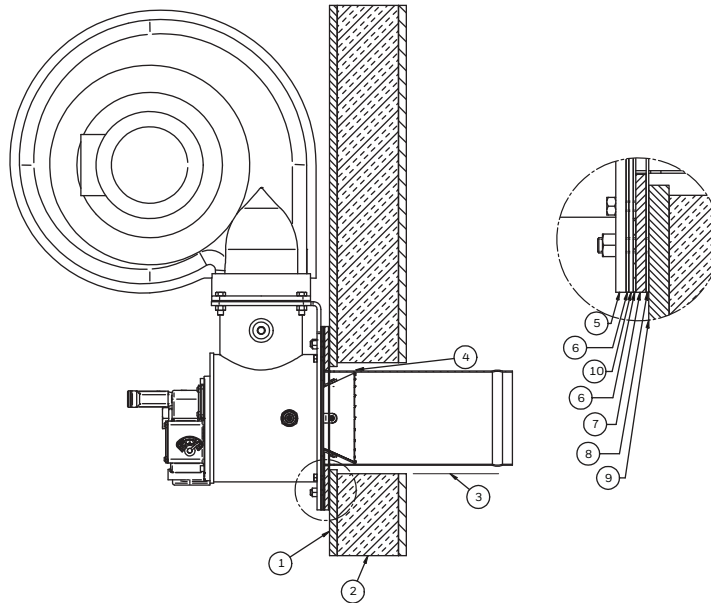

OPLÉ 13, OPLÉ 15, OPLÉ 25, OPLÉ EB40

(OPLÉ 30, 35, 40, 45, 70, EB65, EB100 have all same parts but cone is attached via an internal sleeve)

- 1) Heater shell
- 2) Insulated wall (6" maximum depth)
- 3) Cut opening 1" larger than sleeve diameter
- 4) This area may be packed with insulation up to 2" in depth
- 5) Burner flange
- 6) Gasket supplied with burner
- 7) Discharge sleeve-flange
- 8) Optional gasket
- 9) Heater wall

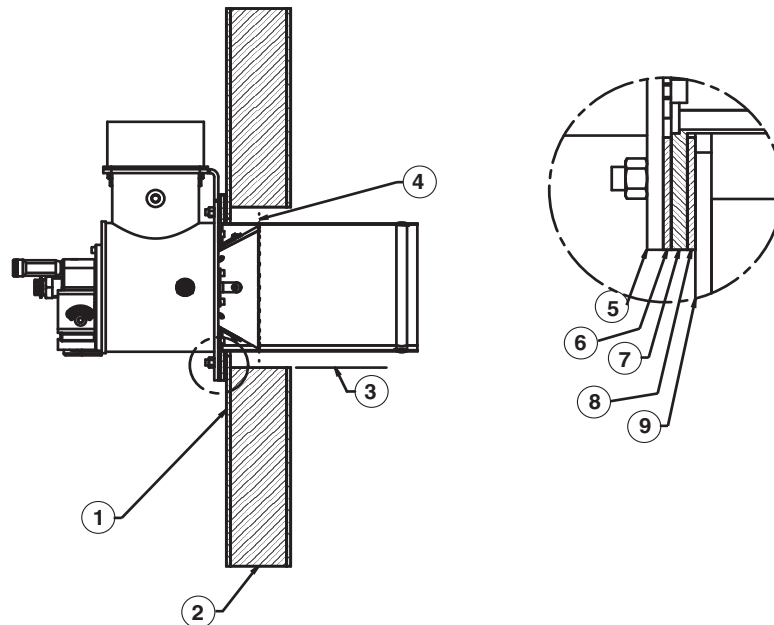

- 1) Ensure heater shell can support burner weight. If not, add a stiffening plate or support burner weight by other means.
- 2) Mounting studs (by others)

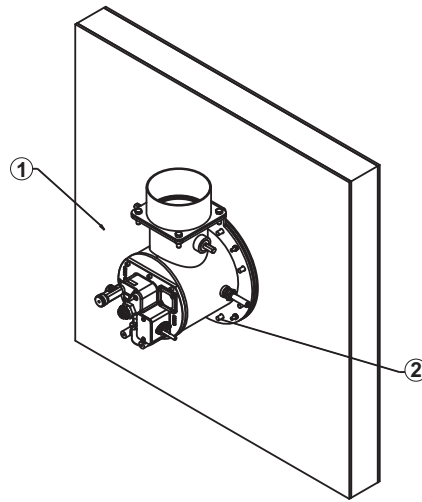

START-UP INSTRUCTIONS

Instructions provided by the company or individual responsible for the manufacture and/or overall installation of a complete system incorporating MAXON burners take precedence over the installation and operating instructions provided by

MAXON. If any of the instructions provided by MAXON are in conflict with local codes or regulations, please contact MAXON before initial start-up of equipment.



Read the combustion system manual carefully before initiating the start-up and adjustment procedure. Verify that all of the equipment associated with and necessary to the safe operation of the burner system has been installed correctly, that all pre-commissioning checks have been carried out successfully and that all safety related aspects of the installation are properly addressed.

Initial adjustment and light-off should be undertaken only by a trained commissioning engineer.

Checks during and after start-up

During and after start-up, check the integrity of the system. Check all bolted connections after first firing (first time on temperature) and retighten if necessary.

Pilot ignition

Before ignition of the pilot, adjust the combustion air to the minimum burner air flow. Pilot will not ignite if too high an air flow exists. Set pilot gas flow to the correct value before pilot ignition attempt.

Main burner ignition

Set correct gas flow for burner minimum capacity before attempt of main burner ignition. After ignition of main burner, allow some time on minimum capacity to allow the burner parts to heat up slowly.

Adjust air/gas ratio, set maximum capacity

Once the main flame is ignited, adjust air/gas ratio of the burner to have the required combustion quality and slowly increase capacity. Do not increase capacity too fast to avoid damage to burner parts or furnace due to excessive temperature gradient.

For OVENPAK® LE, adjust fuel pressures to be always equal to combustion air pressures.

Initial adjustments of burner prior to light off (EB OPLE)

- With the burner not lit and the combustion air fan running, force the system to a purge (or high fire) condition.
- With the system at a purge condition, adjust the combustion air until the required differential combustion air is achieved for high fire.
- Force the system to a light off condition, and adjust the minimum position to the required differential combustion air condition.

Adjustments after burner is lit (EB OPLE)

- Connect a manometer to the combustion air test connection, and differentially to the gas test connection on the burner.
- Adjust the gas on each index until each index is a reading of zero all the way to high fire.

MAINTENANCE & INSPECTION INSTRUCTIONS

Safety requirements

Regular inspection, testing and recalibration of combustion equipment according to the installation manual is an integral part of its safety. Inspection activities and frequencies shall be carried out as specified in the installation manual.

Visual inspections

Regular visual inspection of all connections (air and gas piping to the burner, bolting of the burner to the furnace) and burner flame size and aspect are essential.

Spare parts

Keep local stock of spark ignitor. It is not recommended to keep local stock of other burner parts. Consult installation manual for burner spare parts and system accessories.

MAXON OVENPAK® LE

MAXON

201 East 18th Street
P.O. Box 2068
Muncie, IN 47307-0068
www.maxoncorp.com

Maxon reserves the right to alter specifications and data without prior notice.

Automation and Control Solutions

Honeywell International Inc.
1985 Douglas Drive North
Golden Valley, MN 55422
customer.honeywell.com

® U.S. Registered Trademark
© 2016 Honeywell International Inc.
32M-01004-03 M.S. Rev. 06-16
Printed in United States

