

Eclipse AutoTite Automatic Gas Shut-Off Valves

2000AT Series

Version 2

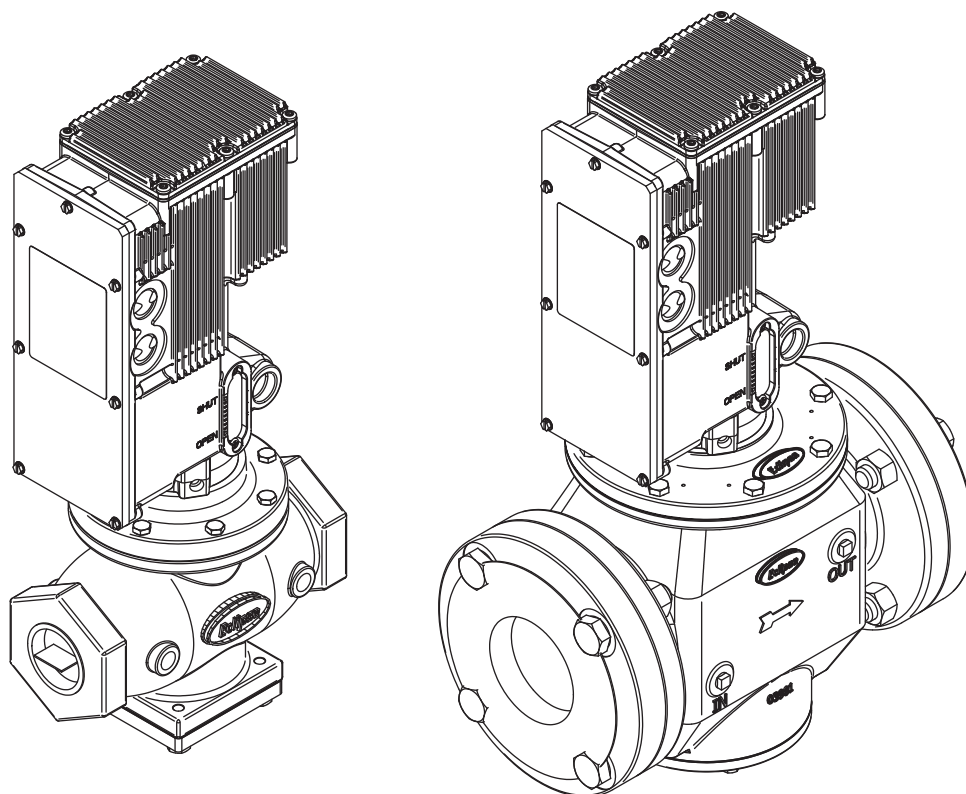

Copyright

Copyright 2011 by Eclipse, Inc. All rights reserved worldwide. This publication is protected by federal regulation and shall not be copied, distributed, transmitted, transcribed or translated into any human or computer language, in any form or by any means, to any third parties, without the express written consent of Eclipse, Inc.

Disclaimer Notice

In accordance with the manufacturer's policy of continual product improvement, the product presented in this brochure is subject to change without notice or obligation.

The material in this manual is believed adequate for the intended use of the product. If the product is used for purposes other than those specified herein, confirmation of validity and suitability must be obtained. Eclipse warrants that the product itself does not infringe upon any United States patents. No further warranty is expressed or implied.

Liability & Warranty

We have made every effort to make this manual as accurate and complete as possible. Should you find errors or omissions, please bring them to our attention so that we may correct them. In this way we hope to improve our product documentation for the benefit of our customers. Please send your corrections and comments to our Technical Documentation Specialist.

It must be understood that Eclipse's liability for its product, whether due to breach of warranty, negligence, strict liability, or otherwise is limited to the furnishing of replacement parts. Eclipse will not be liable for any other injury, loss, damage or expenses, whether direct or

consequential, including but not limited to loss of use, income, or damage to material arising in connection with the sale, installation, use of, inability to use or the repair or replacement of Eclipse's products.

Any operation expressly prohibited in this manual, any adjustment, or any assembly procedures not recommended or authorized in these instructions shall void the warranty.

Document Conventions

There are several special symbols in this document. You must know their meaning and importance.

The explanation of these symbols follows below. Please read it thoroughly.

How To Get Help

If you need help, contact your local Eclipse representative. You can also contact Eclipse at:

1665 Elmwood Rd.
Rockford, Illinois 61103 U.S.A.
Phone: 815-877-3031
Fax: 815-877-3336
<http://www.eclipsenet.com>

Please have the information on the product label available when contacting the factory so we may better serve you.

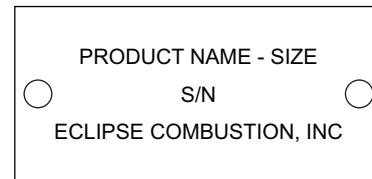

This is the safety alert symbol. It is used to alert you to potential personal injunt hazards. Obey all safety messages that follow this symbol to avoid possible injury or death.



Indicates a hazardous situation which, if not avoided, will result in death or serious injury.



Indicates a hazardous situation which, if not avoided, could result in death or serious injury.



Indicates a hazardous situation which, if not avoided, could result in minor or moderate injury.

NOTICE

Is used to address practices not related to personal injury.

NOTE

Indicates an important part of text. Read thoroughly.



Table of Contents

1 Introduction.....	4
Product Description	4
Additional Features	5
Audience	5
Purpose	5
2 Installation.....	6
Introduction.....	6
Valve Installation	6
Valve/Pipe Connections	6
Actuator Installation.....	7
Actuator Mounting	7
Actuator Wiring.....	8
Operation Checkout	10
3 Maintenance & Troubleshooting.....	11
Introduction.....	11
Maintenance.....	11
Replacement Parts.....	11
Troubleshooting Procedures	11

Introduction

1

Product Description

The Eclipse AutoTite Series 2000AT valve is designed to be an automatic gas supply shut-off to a combustion system. The valve has a 30 psi (2 bar) differential pressure rating and opens smoothly, minimizing any gas pressure surge to downstream components. When either an interlocking switch in the system opens or electrical power fails, the valve closes within one second.

The AutoTite valve is available in sizes of 1" through 3" and is offered with NPT threads. They are UL listed, FM approved and CSA certified. These valves meet the system shut-off requirements of NFPA 86, IRI, FM and EN746-2 which include position indication and proof of closure.

NOTE: NFPA 86 standard requires that burner systems over 150,000 Btu/h (44 kW) be equipped with safety shut-off valves with position indication. It also requires that systems over 400,000 Btu/h (117 kW) include at least one valve that meets a "proven closed" requirement when integrated into the pre-ignition interlock circuit. The 2000AT Valve, with dual proof-of-closure switches, meets both of these requirements.

NOTE: EN746-2 standards require that a closed position switch be provided for interlocking into control systems for verifying position before automatic start-up of burner(s). The 2000AT meets this requirement.

Each AutoTite valve actuator has three switches, two Proof-of-Closure switches and one Auxiliary Switch. The Proof-of-Closure Switches are factory set non-field adjustable SPDT switches. The Auxiliary Switch is not a safety switch and is also a factory set non-field adjustable SPDT switch.

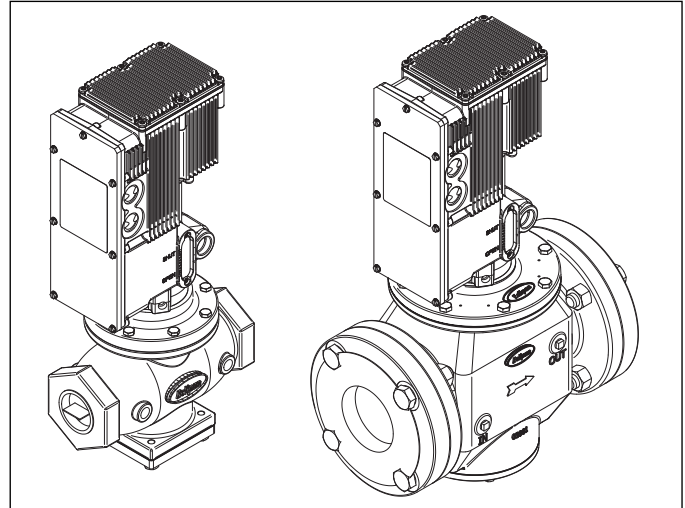

Figure 1.1. Eclipse AutoTite Automatic Gas Shut-Off Valves

The AutoTite valve is available with 110V 50Hz, 120V 60Hz, 220V 50Hz and 240V 60Hz actuators with general purpose, dust tight and drip tight enclosures. These actuators can be rotated 360° for ease of installation. Additional options shown at left are:

The Quick Disconnect Option

The quick disconnect option, which includes an electrical connector, allows quick installation and removal in portable applications, and provides greater maintainability.



Additional Features

- Actuator is field replaceable without removing valve body.
- The valve is not position conscious.
- 1/4" (6.4 mm) ports, located upstream and downstream on both sides of the valve body, can be used for pressure tap fittings, pressure gages, leak detection systems and pressure switch connections.
- One second maximum closing time.
- Positive shut-off using soft-seat disc.
- Three built-in switches.
- Visual indication of valve position.
- Cast iron body with stainless steel internals.
- Factory tested before shipment.

Audience

This manual has been written for personnel already familiar with all aspects of this product.

These aspects are:

- Installation
- Use
- Maintenance
- Safety

The audience is expected to be qualified and have experience with this type of equipment and its working environment.

Purpose

The purpose of this manual is to make sure that you carry out the installation of a safe, effective and trouble-free system.

Installation

2

Introduction

In this section you will find the information and instructions that you need to install the valve and actuator. The 2000AT valve is designed to provide control of gaseous fluid (air, natural gas, propane and butane) flow in applications in which there is minimal exposure to water.



CAUTION

- **The presence of water in the gas can result in corrosion which will limit the life of the valve. Also, at temperatures below 32°F (0°C), the water will freeze which could result in valve failure.**

The 2000AT valve is operated by a hydraulic actuator which allows the valve to close when power is discontinued. When mounted together, the actuator and valve can be installed in any position. Sufficient clearance should be maintained to allow for installation and servicing. See dimensional and mounting information provided in the Datasheet 756-1.

Valve Installation



WARNING

- **Shut off gas supply and disconnect actuator power prior to valve installation.**
 - Gas flow through the valve must be in the direction indicated by the arrow on the valve body: otherwise, the valve may not shut off.
 - The valve must be installed in a location that will remain within the temperature limits stated in the Datasheet 756-1.
 - Do not use the valve to support adjacent piping.
 - Pipe must be free of scale or other foreign materials before connecting to the valve body.
 - A strainer shall be installed in the gas line upstream of the shut-off valve to prevent the ingress of foreign matter which can damage the valve and cause leakage.
 - For ease of installation, install the valve body prior to attaching the actuator. This will also prevent possible actuator damage.
 - Do not remove the protective plastic cap from the top of the valve until just before installing the actuator.

NOTE: Prior to installation, ensure that there will be 2" (51 mm) clearance above the actuator to allow for installation or removal.

Valve / Pipe Connections

1" through 2" Sizes

1. Remove the protective caps from the ends of the valve.
2. Apply a moderate amount of pipe sealant to the **male pipe threads only**.

NOTE: Excessive pipe sealant could contaminate the valve seat, thus preventing the valve from closing properly.

3. Install the valve with the flow in the direction of the arrow on the valve body.
4. Tighten the pipe into the valve body, reacting the torque at the cast hex portion of the valve body, adjacent to that pipe.

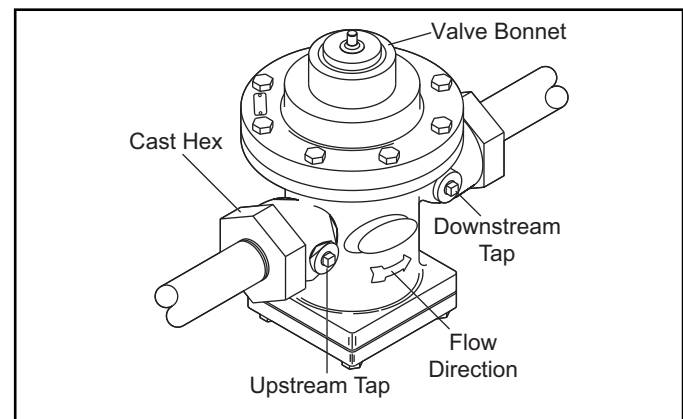

Figure 2.1

2-1/2" through 3" Sizes, Threaded Flanges

1. Apply a moderate amount of pipe sealant to the **male pipe threads only**.
2. Insert the pipe into the flanges and tighten. Wipe excess pipe sealant from the inside of the pipe/flange connection. Handle the flanges in a manner which will prevent damage to the seal face.

NOTE: Excessive pipe sealant could contaminate the valve seat, thus preventing the valve from closing properly.

3. Remove the plastic caps from the ends of the valve. Handle the valves in a manner to prevent damage to the flange seal face.
4. Install the valve into the gas line with the flow in the direction of the arrow on the valve body.
5. Attach the pipe flanges to the valve flanges, installing gaskets between them. Make sure the gasket lies flat between the flanges.
6. Tighten the four bolts on each flange so that the faces bear uniformly on the gasket. **Torque the nuts to 61 - 75 lb-ft (82.7 - 101.7 Nm).**

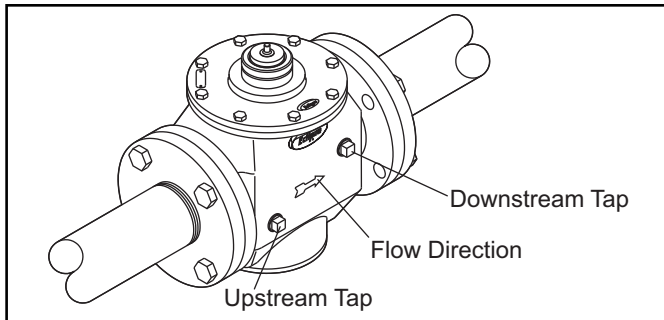

Figure 2.2

2-1/2" through 3" Sizes, Weld-On Flanges

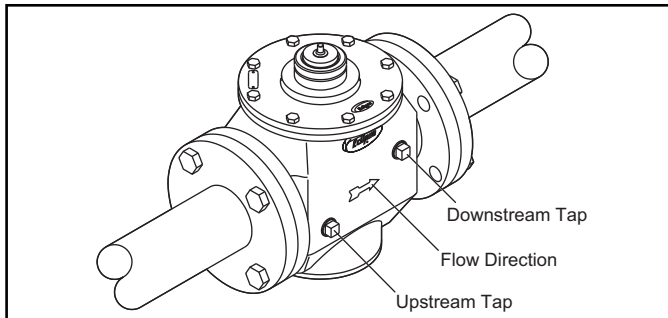

Figure 2.3

1. Remove the plastic caps from the ends of the valve. Handle the valves in a manner to prevent damage to the flange seal face.
2. Attach the pipe flanges to the valve flanges, installing gaskets between them. Make sure the gasket lies flat between the flanges.
3. Tighten the four bolts on each flange so that the faces bear uniformly on the gasket. **Do not torque at this time.**
4. Install the valve into the gas line with the flow in the direction of the arrow on the valve body. Insert the pipe into the flanges, stopping approximately 1/4" (6 mm) from the flange face.
5. Tack weld the flanges to the pipe using a suitable filler material which is compatible with the ASTM A105 forged steel flanges and the steel pipe being used (probably ASTM A53 or A106).

NOTE: Surfaces for welding shall be clean and free of paint, oil, rust, scale or other material which is detrimental to welding.

6. Unbolt and remove the valve. Apply fillet welds on the inside and outside between the flanges and the pipe. The inside weld is not to extend beyond the face of the flange.
7. Reinstall the valve into the gas train. Attach the pipe flanges to the valve flanges, installing gaskets between them. Make sure the gasket lies flat between the flanges.
8. Tighten the four bolts on each flange so that the faces bear uniformly on the gasket. **Torque the nuts to 61 - 75 lb-ft (82.7 - 101.7 Nm).**

Actuator Installation



- **Shut off power before attaching wires to the actuator to prevent electrical shock.**

- The actuator installs directly to the valve bonnet and is secured by four set screws.
- The actuator should be positioned to allow access for making wire connections. Two knockouts for 1/2" (12.7 mm) conduit are located on each side of the actuator.
- Wiring of actuators must be carried out by a competent person, who will comply with current regulations, standards and requirements.
- After actuator installation is complete, check out the valve-actuator operation per the instructions defined in the "Operation Checkout" section on page 10.

Actuator Mounting

1. Remove the plastic protective cap from the valve bonnet.
2. Loosen the four set screws in actuator collar using a 5/32 allen wrench. Back them out enough to clear the valve bonnet when the actuator is installed. (Photo A)
3. Slip the actuator onto the valve bonnet and rotate the actuator to the desired position to accommodate wiring. The actuator weight is approximately 20 lb (9 kg). Press firmly.
4. Tighten each of the three set screws in the actuator collar evenly (Photo C) until resistance is felt as the set screw contacts the V-Groove of the bonnet (Photo D). Torque each set screw to 75 - 95 lb-in (8.5 - 10.7 Nm).

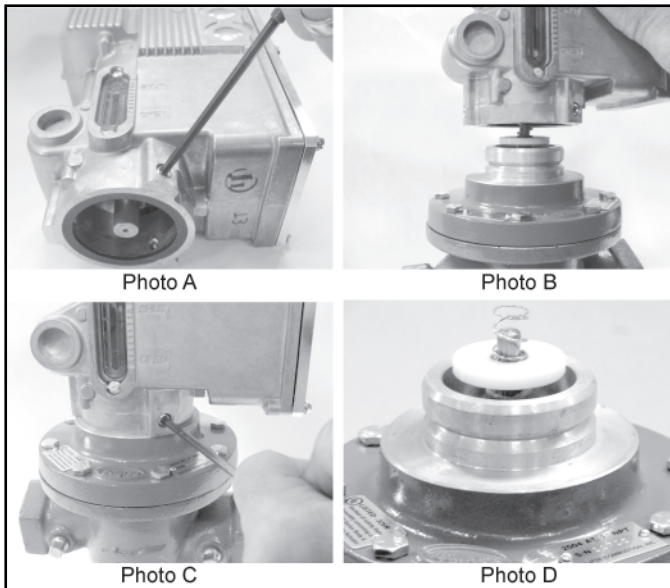

Figure 2.4

Actuator Wiring



WARNING

- Shut off power before making electrical connections. Failure to do so could result in electrical shock or equipment damage.

NOTE: Wiring must comply with all applicable state and local electrical codes, ordinances and regulations.

- Check the nameplate and confirm that the appropriate power is being supplied to the unit. Remove the front cover (with nameplate) and set aside to access electrical connections taking care not to damage the cover gasket if supplied. A diagram is located on the inside of the cover to aid in making electrical connections.
- Remove the desired electrical knock out and install appropriate electrical fittings. Use Type 4 fittings. Route wiring through the fitting. Take care not to scratch or otherwise damage the cover sealing surface when working on watertight enclosure.



CAUTION

- Conduit must be attached to the actuator housing using a connector that is listed for drip tight service (NEMA 4) to maintain the enclosure rating. For example, use a Thomas & Betts hub connector Catalog Number 370, when attaching rigid and intermediate type conduit.

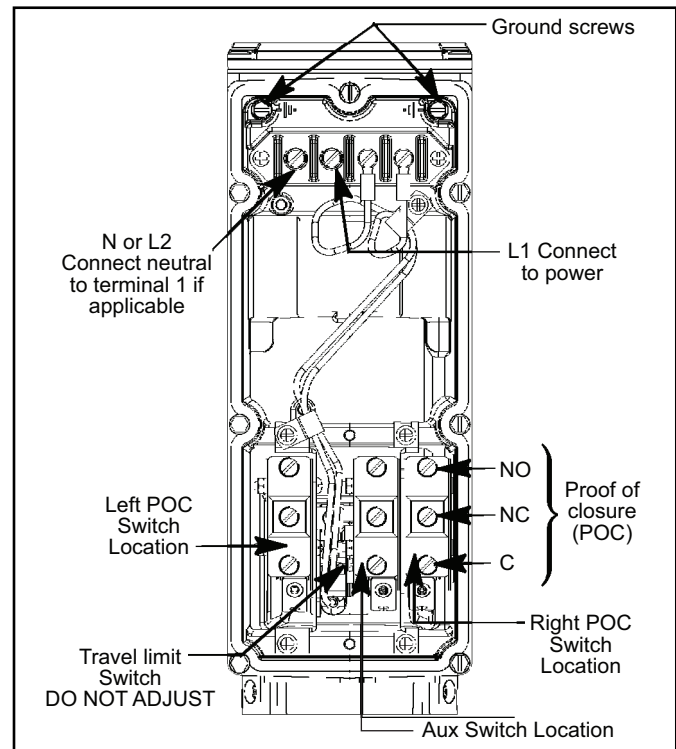

Figure 2.5 Internal Wiring Connections

- Connect the power to terminals 1 and 2. The neutral wire, if applicable, should be connected to terminal 1. Connect the ground wire to the grounding screw provided on the housing next to the terminal strip.
- Torque terminal screws: 8 - 12 in-lbs (0.9 - 1.3 Nm). Torque ground screw: 20 - 25 in-lbs (2.3 - 2.8 Nm).
- For electrical connections of the proof of closure and the auxiliary switch, use the markings located on the insulators to determine normally open and normally closed terminals. Torque electrical connection screws 8 - 12 in-lbs (0.9 - 1.3 Nm). Proof of closure switches are set at the factory. Do not adjust proof of closure switches or the auxiliary switch.
- Install the cover. Be certain that the gasket and sealing surfaces are clean and there is no damage to the surfaces or gasket. Avoid pinching wire by assuring that all wiring is clear of the mating surfaces. Snug down all screws before tightening. Torque screws to 20 - 25 in-lbs (2.3 - 2.8 Nm) evenly using a crisscross pattern starting in the middle and not in the corner.
- Operate actuator (with valve) through five cycles to verify proper operation prior to use.

After installation is complete, cycle the valve several times (with the main manual gas shut-off valve closed) by energizing and de-energizing the actuator to open and close the valve.

STANDARD ACTUATOR

For supply connections, use wires suitable for at least 90°C (194°F)

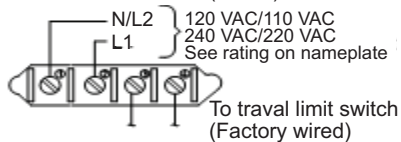

Disregard embossed marking on switches
switches make contacts as shown:
Valve Closed = "C" to "NC"
Valve Opened = "C" to NO"

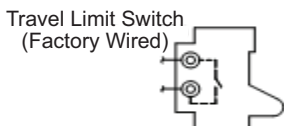
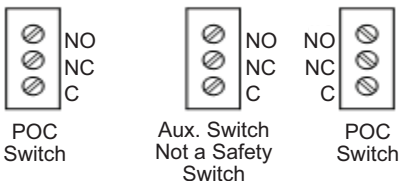

Total connected load of Aux. and proof of closure switches not to exceed 1800 VA.

Aux. and proof of closure switch Ratings: 120 VAC 240 VAC

Aux. 15A 7.5A
Proof of closure 15A 7.5A

426155-001

QUICK DISCONNECT OPTION

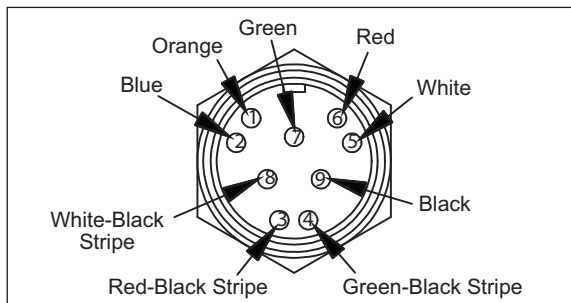

QUICK DISCONNECT CONNECTOR PIN / WIRE IDENTIFICATION

PIN	Wire Color	Connection
1	Orange	Proof-of-closure, switch 2, normally closed (NC) terminal
2	Blue	Proof-of-closure, switch 1, normally closed (NC) terminal
3	Red-black stripe	Auxiliary switch open position, common (C) terminal
4	Green-black stripe	Proof-of-closure, switch 1, common (C) terminal
5	White	Neutral terminal (L2)
6	Red	Auxiliary switch open position, normally open (NO) terminal
7	Green	Ground terminal (earth connection)
8	White-black stripe	Proof-of-closure, switch 2, common (C) terminal
9	Black	Hot terminal (L1)

Figure 2.6 External Wire Connections

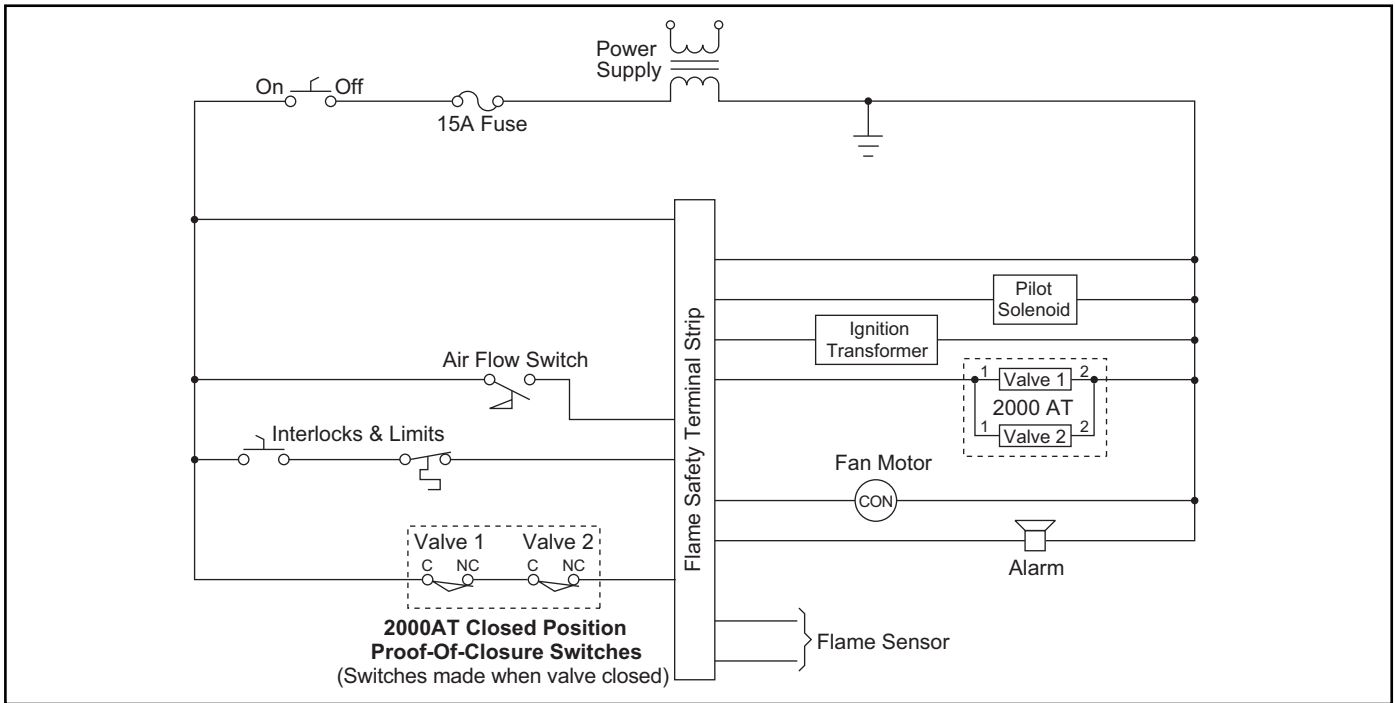

Figure 2.7 Typical Veri-Flame Combustion Safeguard Wiring Diagram Using Two 2000AT Valves per NFPA 86 or EN 746-2 Requirements as Applicable

Operation Checkout



WARNING

- Do not allow fuel to accumulate in the combustion chamber. Fuel/air mixture could be explosive.



CAUTION

- Do not put system into service until proper checkouts have been performed. All tests to be performed by a trained technician. Close all manual shut-off valves as soon as trouble occurs. Failure to do so could result in explosion.

Maintenance and Troubleshooting

Introduction

In this section, you will find the information and instructions that you need to maintain and troubleshoot the valve and actuator. There is also information to order replacement parts as needed.

Maintenance



WARNING

- Turn off gas and disconnect electric supply before working on the valve and/or actuator. Service should be carried out by a competent person, who will comply with current regulations, standards and requirements.

Scheduled Maintenance

- Set up an inspection and maintenance schedule for the 2000AT automatic shut-off valve and other valve train components.
- Inspect and clean or replace the strainer or filter screen installed upstream of the valve as required.
- Cycle the actuator/valve periodically. Interrupt electrical power to simulate an unsafe condition. If the valve does not close within one second, remove it from service and replace with a new unit.

Troubleshooting Procedures

Problem	Possible Cause	Solution
Valve will not open	No power at actuator	Check power to actuator. Correct system problem.
	Actuator is incorrectly wired	Check power to actuator. Rewire power to terminals 1 & 2.
	Actuator is not functioning	Remove actuator from valve body and energize. Replace actuator.
	Valve is stuck	Replace valve and actuator.
Valve will not seal when closed	Contamination or mechanical damage	Valve body not field serviceable; replace valve and actuator.
Switch not made	Mechanical/electrical failure	Cycle valve (open/close) while checking valve with multi-meter. Contact Eclipse.
	Switch is incorrectly wired	Check power to switch. Rewire switch.

- Perform a valve seat leak test with procedures that meet local standards and codes (reference NFPA 86). If the leakage rate is greater than the standard allows, remove the valve and replace with a new one.
- None of the components in the valve body assembly are replaceable and therefore should not be serviced in the field.



WARNING

- Proof of Closure and Auxiliary switches are factory set and are not recommended to be replaced or adjusted in the field. Please contact Eclipse if any of the three switches require replacement.

Replacement Parts

Actuator Replacement Part Numbers		
Voltage	Part No.	NEMA Rating
110/120V	10054585	1, 3, 4 Standard
220/240V	10054586	1, 3, 4 Standard
110/120V	10056102	1, 3, 4 Quick Disconnect

