

ECLIPSE INFORMATION GUIDE

Nozzle Mixing Pilots

Series NMP-S

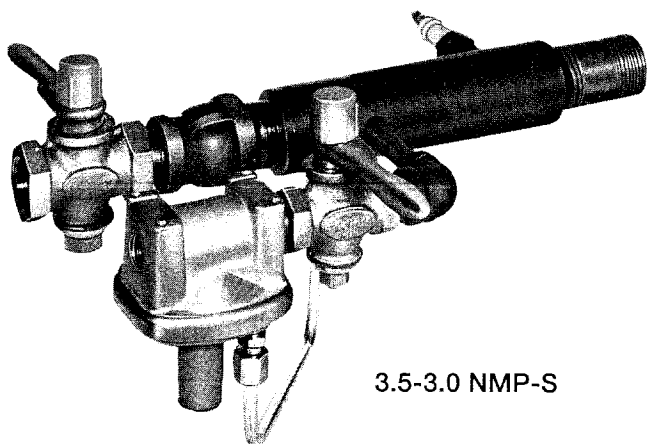

3.5-3.0 NMP-S

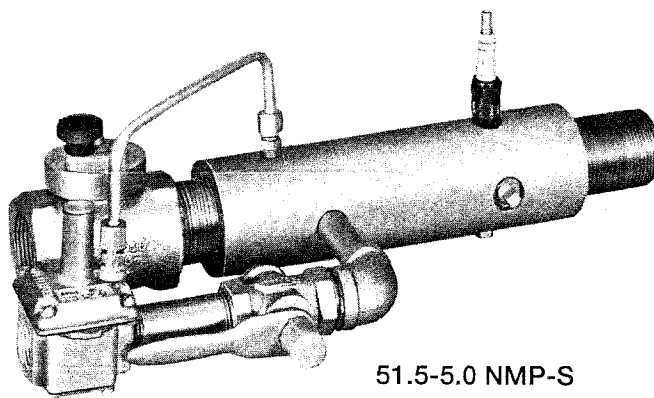

51.5-5.0 NMP-S

Eclipse Nozzle Mixing Pilots (NMP) are designed to reliably ignite all types of gas, oil, or combination gas/oil burners. NMP-S pilots feature easy ignition and extremely stable

operation with air/gas ratios ranging from 50% fuel rich to over 600% excess air. Performance under varying operating conditions is excellent.

1.0 Operating Parameters & Requirements

Capacities & Pressures	See the individual capacities charts in Figures 2 and 3.
Pilot Fuel	Natural or LP gas.
Fuel/Air Ratio	From 50% fuel rich to over 600% excess air.
Ignition Plug Supply Power	6000 Volts minimum at 120 VA.
Main Burner Backpressure	Normally not critical, but backpressure must be added to normal pilot air and gas pressures to insure reliable pilot operation. Some types of high velocity burners will produce such a rapid increase in backpressure on lightoff that the pilot cannot be set to operate reliably under both pre- and post-lightoff conditions. In such cases, a bypass pilot may be a better choice.

2.0 Installation

Pilot Thread Coating	Coat the pilot threads with John Crane Thred-Gard High Temperature Anti-Seize compound or equivalent before attaching the pilot to the burner.
Ignition Plug Placement	Position the ignition plug at the top of the pilot; condensation, which can cause ignition failure, is less likely to occur there.



ECLIPSE COMBUSTION

Figure 1 – 3.5 Series Capacities & Dimensions

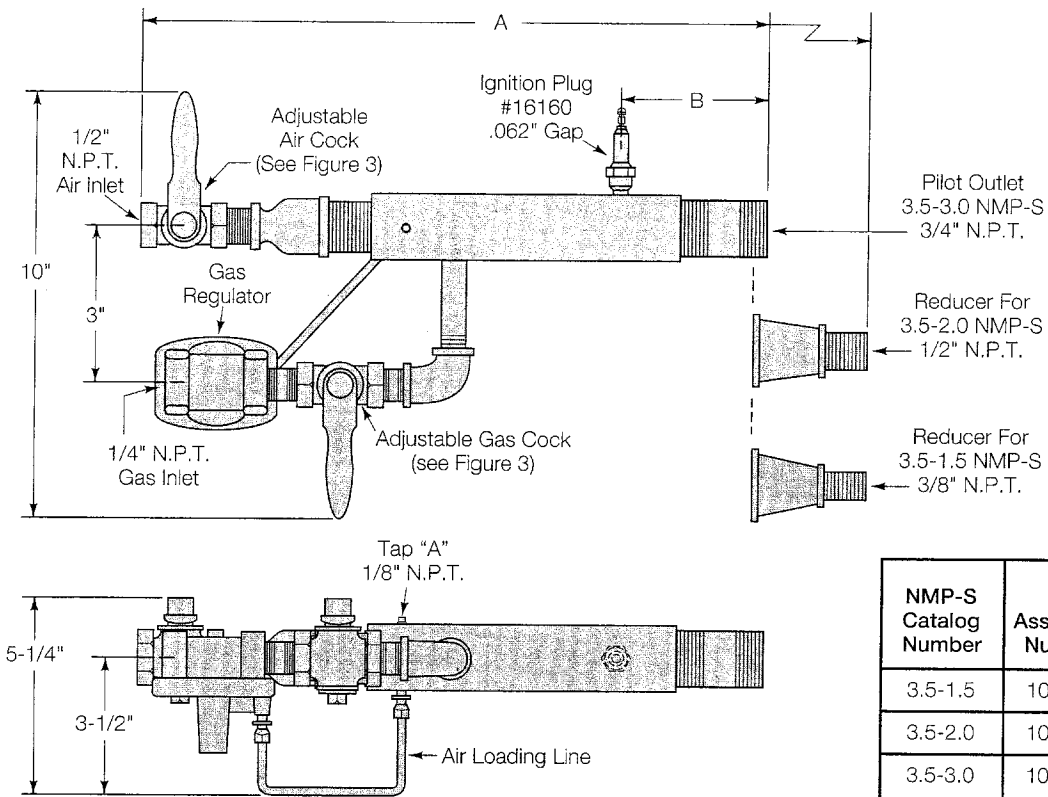

NMP-S Catalog Number	Assembly Number	Dimensions In Inches	
		A	B
3.5-1.5	102600	12-1/8	4
3.5-2.0	102599	12-3/8	4-1/4
3.5-3.0	102598	10-7/8	2-3/4

Capacities

Using Natural Gas – 0.6 Specific Gravity

NOTE: These pressures are for estimating supply requirements only.
Use Figure 4 for actual pilot set-up.

3.5-1.5 NMP-S

Capacity In 1000's Btu/hr.	5	10	15	20	25
Min. Air Press. Required, "w.c.*	5	5	8	12	12
Min. Gas Press. Required, "w.c.**	6	6	8	10	10
Approx. Flame Length, Inches	5	7	9	11	12

3.5-2.0 & 3.5-3.0 NMP-S

Capacity In 1000's Btu/hr.	5	10	15	20	25
Min. Air Press. Required, "w.c.*	3	3	5	8	8
Min. Gas Press. Required, "w.c.**	4	4	5	6	6
Approx. Flame Length, Inches	5	7	9	11	12

* Measured at inlet to adjustable air cock. Add any burner block backpressures to these figures.

** Measured at inlet to gas regulator. Add any burner block backpressures to these figures.

Figure 2-51.5 Series Capacities & Dimensions

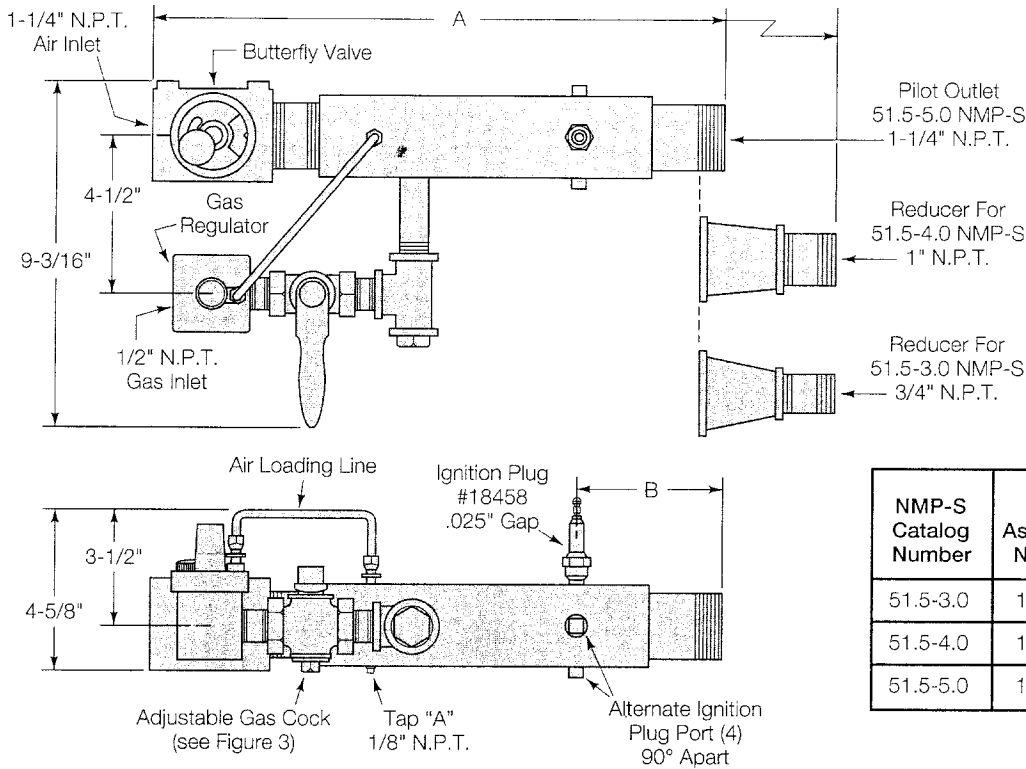

NMP-S Catalog Number	Assembly Number	Dimensions In Inches	
		A	B
51.5-3.0	102722	17-3/8	6-1/2
51.5-4.0	102721	17-1/4	6-3/8
51.5-5.0	102720	14-9/16	3-11/16

Capacities

Using Natural Gas - 0.6 Specific Gravity

NOTE: These pressures are for estimating supply requirements only. Use Figure 4 for actual pilot set-up.

51.5-3.0 NMP-S

Capacity In 1000's Btu/hr.	6	15	25	35	45	55	65
Min. Air Press. Required, "w.c.*	4	4	4	4	8	8	8
Min. Gas Press. Required, "w.c.**	5	5	5	5	10	10	10
Approx. Flame Length, Inches	6	9	12	14	15	16	17

51.5-4.0 NMP-S

Capacity In 1000's Btu/hr.	6	30	50	70	90
Min. Air Press. Required, "w.c.*	4	4	4	8	8
Min. Gas Press. Required, "w.c.**	4	4	4	10	10
Approx. Flame Length, Inches	6	17	18	20	21

51.5-5.0 NMP-S

Capacity In 1000's Btu/hr.	6	30	60	90	120	150
Min. Air Press. Required, "w.c.*	4	4	4	8	8	8
Min. Gas Press. Required, "w.c.**	4	4	4	10	10	10
Approx. Flame Length, Inches	5	11	17	19	20	20

* Measured at inlet to adjustable air cock. Add any burner block backpressures to these figures.

** Measured at inlet to gas regulator. Add any burner block backpressures to these figures.

3.0 Set-Up And Adjustment

Shut Off Gas Supply

Turn the gas cock handle to the closed position as shown in Figure 1 or 2. Turn the gas adjusting screw fully clockwise.

Adjust Airflow

Set the main burner combustion air at its normal startup flow.

3.5 Series: Remove the spark plug and install a 1/8" N.P.T. hose fitting. Connect a manometer between pressure tap "A" (Figure 1) and the ignition plug hole. Referring to Figure 4, turn the adjusting screw of the adjustable air cock (Figure 3) until the measured air pressure drop corresponds to the desired pilot firing rate. Replace the spark plug.

51.5 Series: Connect a manometer between pressure tap "A" (Figure 2) and the spare ignition plug hole. Referring to Figure 4, adjust the air butterfly valve until the measured air pressure drop corresponds to the desired pilot firing rate.

Light Pilot

With the spark plug energized, turn the handle of the adjustable gas cock (Figure 3) to the open position, then turn the gas adjusting screw counterclockwise until the pilot lights.

Adjust Pilot Flame

Turn the gas adjusting screw until the flame monitoring device is activated and reliably ignites the main burner. Once the pilot and main burner are lit, recheck the pilot with startup gas flowing because the resulting higher burner block pressure may affect the pilot.

Figure 3—Adj. Orifice Cock

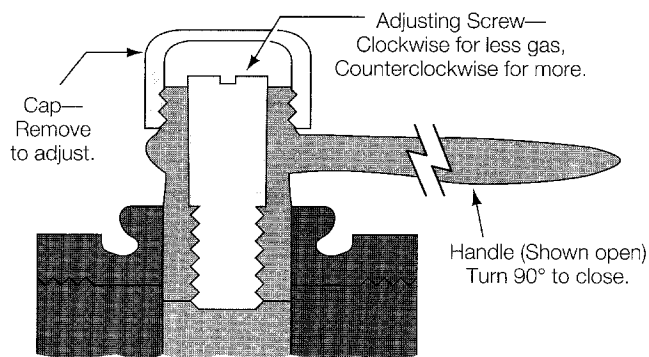
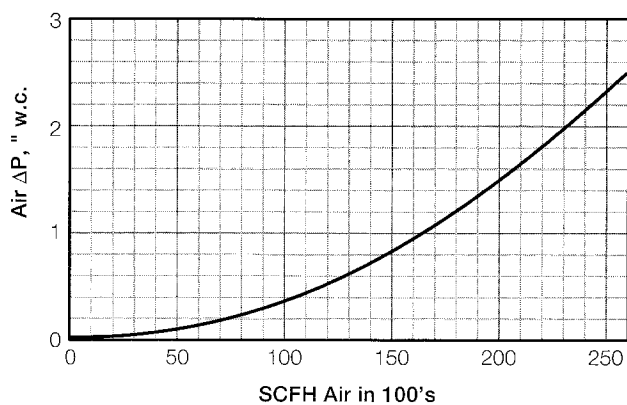

Figure 4 – Air Flow Data

For 3.5 Series NMP-S



For 51.5 Series NMP-S

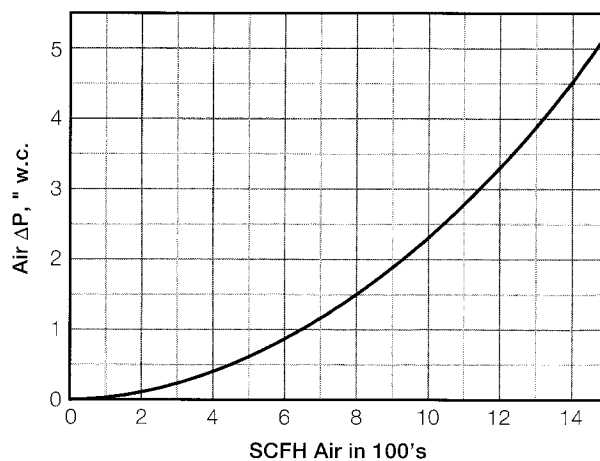
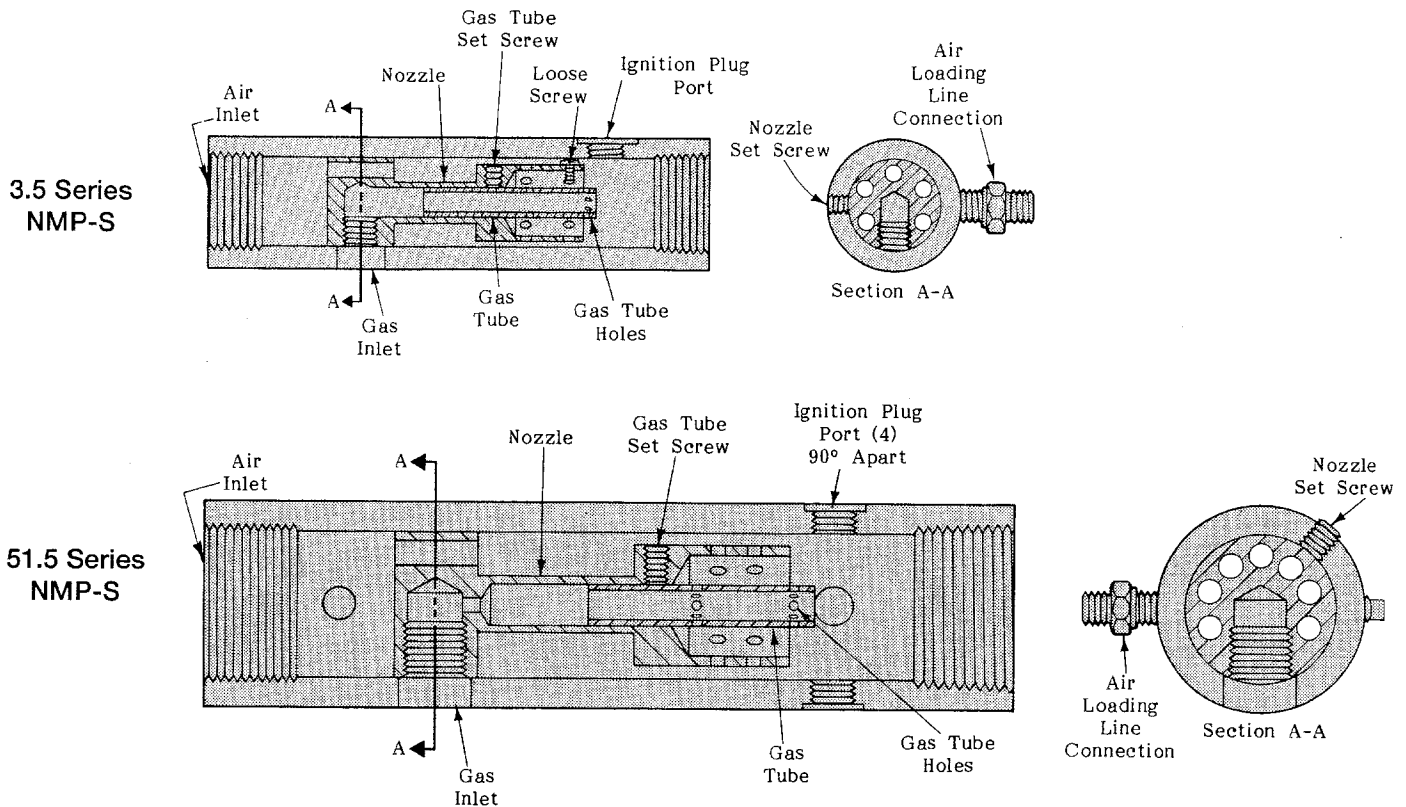

Figure 5 – Assembly Details



4.0 Maintenance

Pilot Removal

Turn off the gas supply upstream of the pilot. Disconnect air and gas lines to the pilot and remove the pilot from the burner.

Disassembly

Remove the ignition plug.

Remove the air loading line from the gas regulator and pilot body.

Unscrew the gas valve train from the pilot body.

Remove the nozzle set screw (refer to Figure 5). Slide the nozzle out of the pilot body. Note the location of the loose screw in the nozzle of the 3.5 Series pilot. This screw creates air turbulence upstream of the ignition plug electrode and is required for reliable pilot ignition. Loosen the gas tube set screw and pull the gas tube from the nozzle.

Parts Maintenance

Clean any parts that are dirty, corroded, or carbon fouled. Clean the spark plug and check the gas as listed in Figures 1 or 2.

Reassembly

Insert a slightly undersized drill rod into the holes at the discharge end of the gas tube. Slide the gas tube into the nozzle until the drill rod rests flush against the nozzle. Tighten the gas tube set screw enough to secure the gas tube, but allow removal of the drill rod. After removing the drill rod, finish tightening the set screw. For the 3.5 Series, insert the loose screw into the hole in the nozzle, as shown in Figure 5, which will place the screw directly upstream of the ignition plug. Slide the nozzle back into the pilot body and screw the gas valve train into the nozzle connection. Tighten the nozzle set screw.

Screw the gas valve train to the pilot body.

Replace the air loading line from the gas regulator and pilot body.

Reinstall the pilot on the burner.