

# *Eclipse Winnox Burners*

*WX Series  
Version 3*

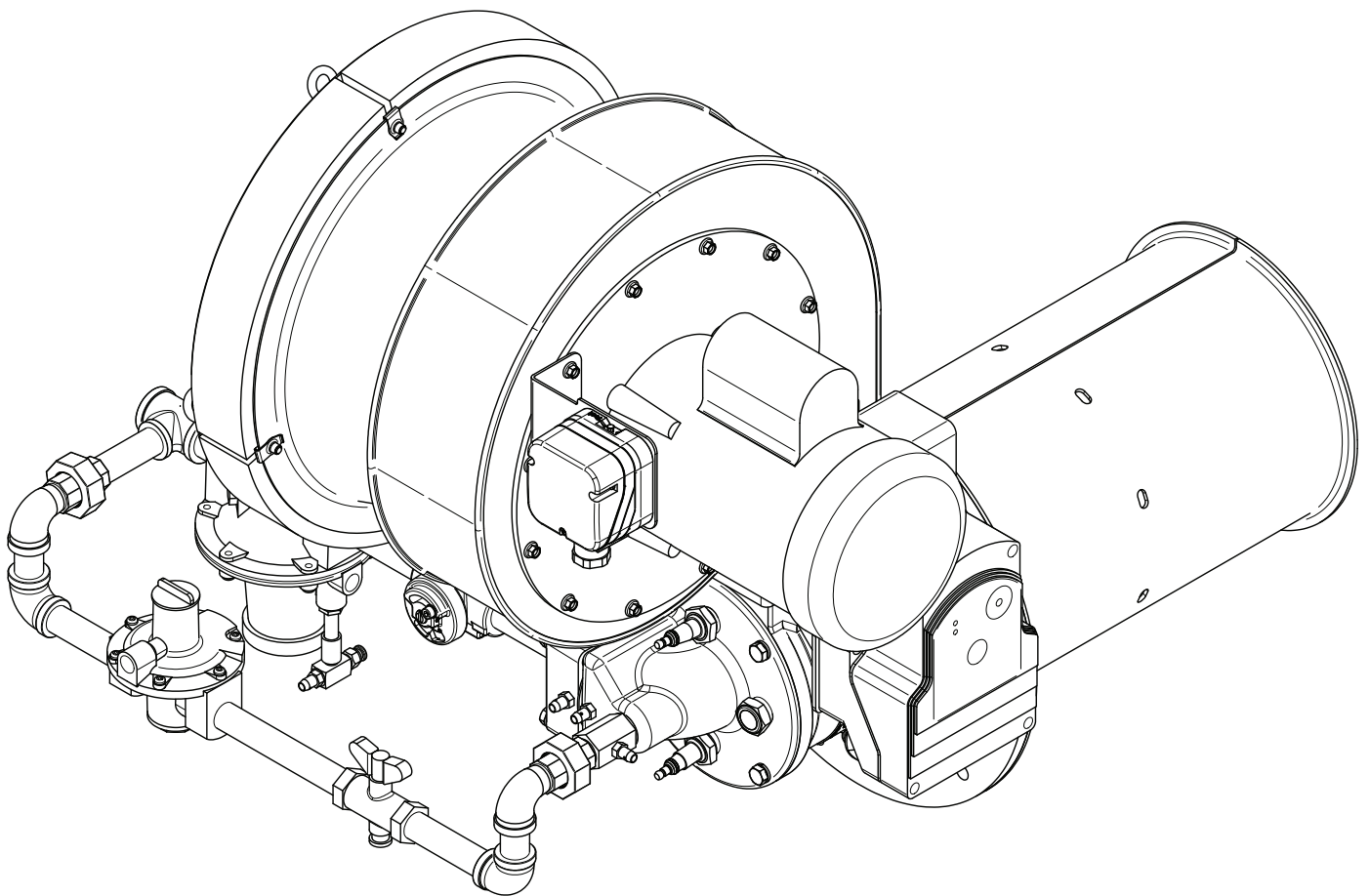

## Copyright

Copyright 2007 by Honeywell International Inc. All rights reserved worldwide. This publication is protected by federal regulation and shall not be copied, distributed, transmitted, transcribed or translated into any human or computer language, in any form or by any means, to any third parties, without the express written consent of Honeywell Eclipse.

## Disclaimer Notice

In accordance with the manufacturer's policy of continual product improvement, the product presented in this brochure is subject to change without notice or obligation.

The material in this manual is believed adequate for the intended use of the product. If the product is used for purposes other than those specified herein, confirmation of validity and suitability must be obtained. Honeywell Eclipse warrants that the product itself does not infringe upon any United States patents. No further warranty is expressed or implied.

## Liability & Warranty

We have made every effort to make this manual as accurate and complete as possible. Should you find errors or omissions, please bring them to our attention so that we may correct them. In this way we hope to improve our product documentation for the benefit of our customers. Please send your corrections and comments to our Technical Documentation Specialist.

It must be understood that Honeywell Eclipse's liability for its product, whether due to breach of warranty, negligence, strict liability, or otherwise is limited to the furnishing of replacement parts and Honeywell Eclipse will not be liable for any other injury, loss, damage or

expenses, whether direct or consequential, including but not limited to loss of use, income, or damage to material arising in connection with the sale, installation, use of, inability to use, or the repair or replacement of Honeywell Eclipse's products.

Any operation expressly prohibited in this manual, any adjustment, or assembly procedures not recommended or authorized in these instructions shall void the warranty.

## Document Conventions

There are several special symbols in this document. You must know their meaning and importance.

The explanation of these symbols follows below. Please read it thoroughly.

## How To Get Help

If you need help, contact your local Honeywell Eclipse representative. You can also contact Honeywell Eclipse at:

1665 Elmwood Rd.  
Rockford, Illinois 61103 U.S.A.  
Phone: 815-877-3031  
Fax: 815-877-3336

Please have the information on the product label available when contacting the factory so we may better serve you.

 <b>ECLIPSE</b> <small>Innovative Thermal Solutions</small>	<a href="http://www.eclipsenet.com">www.eclipsenet.com</a>
Product Name	
Item #	
S/N	
DD MMM YYYY	



This is the safety alert symbol. It is used to alert you to potential personal injury hazards. Obey all safety messages that follow this symbol to avoid possible injury or death.



Indicates a hazardous situation which, if not avoided, will result in death or serious injury.



Indicates a hazardous situation which, if not avoided, could result in death or serious injury.



Indicates a hazardous situation which, if not avoided, could result in minor or moderate injury.

**NOTICE**

Is used to address practices not related to personal injury.

**NOTE**

Indicates an important part of text. Read thoroughly.

# Table of Contents

<b>Introduction</b> .....	<b>4</b>
Product Description .....	4
Audience .....	4
Winnox Documents .....	4
Purpose .....	4
<b>Safety</b> .....	<b>5</b>
Introduction .....	5
Safety .....	5
Capabilities .....	5
Operator Training .....	5
Replacement Parts .....	5
<b>System Design</b> .....	<b>6</b>
Design .....	6
Step 1: Burner Model Selection .....	6
Step 2: Packaged Blower Option Selection .....	8
Step 3: Control Methodology .....	8
Step 4: Ignition System .....	9
Step 5: Flame Monitoring Control System .....	9
Step 6: Main Gas Shut-Off Valve Train .....	10
Step 7: Verify Chamber Design .....	10
<b>System Summary</b> .....	<b>11</b>

# Introduction

# 1

## **Product Description**

The Winnox is a nozzle-mix, low-emissions burner designed for direct and indirect air heating, as well as oven applications up to 1800°F (980°C).

The burner package includes a combustion air blower and ratio regulator to fire over a wide gas turndown range at a controlled ratio.

The burner is designed for:

- low NO<sub>x</sub> and CO emissions
- efficient ratio controlled combustion
- reliable burner operation
- simple burner adjustment
- direct spark ignition
- multiple fuel capability

The wide variety of options and configurations are available due to the modular design of the burner.

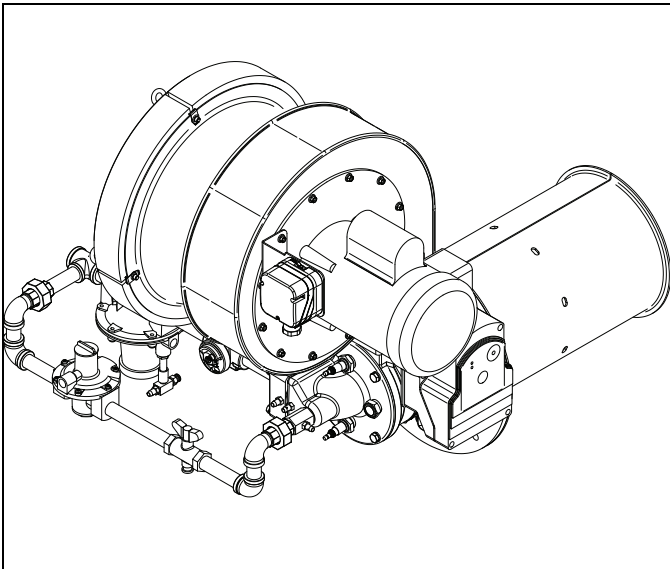

**Figure 1.1 Winnox Burner**

## **Audience**

This manual has been written for people who are already familiar with all aspects of a nozzle-mix burner and its add-on components, also referred to as “the burner system”.

These aspects are:

- Design / Selection
- Use
- Maintenance

The audience is expected to have previous experience with this type of equipment.

## **Winnox Documents**

### **Design Guide No. 111**

- This document

### **Datasheet, Series 111**

- Available for individual WX models
- Required to complete design and selection

### **Installation Guide No. 111**

- Used with Datasheet to complete installation

### **Related Documents**

- EFE 825 (Combustion Engineering Guide)
- Eclipse Bulletins and Info Guides: 710, 732, 756, 760, 930

## **Purpose**

The purpose of this manual is to ensure the design of a safe, effective, and trouble-free combustion system.

Important notices which help provide safe burner operation will be found in this section. To avoid personal injury and damage to the property or facility, the following warnings must be observed. All involved personnel should read this entire manual carefully before attempting to start or operate this system. If any part of the information in this manual is not understood, contact Eclipse before continuing.

## Safety Warnings



### **DANGER**

- **The burners, described herein, are designed to mix fuel with air and burn the resulting mixture. All fuel burning devices are capable of producing fires and explosions if improperly applied, installed, adjusted, controlled or maintained.**
- **Do not bypass any safety feature; fire or explosion could result.**
- **Never try to light a burner if it shows signs of damage or malfunction.**



### **WARNING**

- **The burner and duct sections are likely to have HOT surfaces. Always wear the appropriate protective equipment when approaching the burner.**
- **Eclipse products are designed to minimize the use of materials that contain crystalline silica. Examples of these chemicals are: respirable crystalline silica from bricks, cement or other masonry products and respirable refractory ceramic fibers from insulating blankets, boards, or gaskets. Despite these efforts, dust created by sanding, sawing, grinding, cutting and other construction activities could release crystalline silica. Crystalline silica is known to cause cancer, and health risks from the exposure to these chemicals vary depending on the frequency and length of exposure to these chemicals. To reduce the risk, limit exposure to these chemicals, work in a well-ventilated area and wear approved personal protective safety equipment for these chemicals.**

### **NOTICE**

- **This manual provides information regarding the use of these burners for their specific design purpose. Do not deviate from any instructions or application limits described herein without written approval from Eclipse.**

## Capabilities

Only qualified personnel, with sufficient mechanical aptitude and experience with combustion equipment, should adjust, maintain or troubleshoot any mechanical or electrical part of this system. Contact Eclipse for any needed commissioning assistance.

## Operator Training

The best safety precaution is an alert and trained operator. Train new operators thoroughly and have them demonstrate an adequate understanding of the equipment and its operation. A regular retraining schedule should be administered to ensure operators maintain a high degree of proficiency. Contact Eclipse for any needed site-specific training.

## Replacement Parts

Order replacement parts from Eclipse only. All Eclipse approved valves or switches should carry UL, FM, CSA, CGA and/or CE approval where applicable.

# System Design

# 3

## Design

The design process is divided into the following steps:

### 1. Burner Option Selection Including:

- Burner Model / Size Selection
- Firing Position
- Burner Configuration
- Fuel Type
- Pilot Configuration
- Combustor Type
- Air Supply
- Control Motor
- Limit Switch
- Loading Line Type
- Air Pressure Switch
- Pipe Connections
- Flame Supervision

### 2. Packaged Blower Option Selection Including:

- Power Supply Frequency
- Pressure & Flow
- Blower Motor Type
- Blower Inlet
- Blower Configuration

### 3. Control Methodology Including:

- Burner Control

### 4. Ignition System Including:

- Ignition Transformer
- Trial for Ignition
- Ignition Gas Piping

### 5. Flame Monitoring Control System Including:

- Flame Sensor
- Flame Monitoring Control

### 6. Main Gas Shut-Off Valve Train Including:

- Component Selection
- Fuel Flow Measurement
- Valve Train Size

### 7. Verify Chamber Design:

- Firing Chamber Dimensions
- Flame Shielding

## Step 1: Burner Option Selection

Step 1 describes how to select burner options to suit an application. Use the Winnox Price List and Datasheets, series 111 when following this selection process.



**CAUTION**

- **Consult EFE-825 Eclipse Engineering Guide or contact Eclipse if you have special conditions or questions.**

### **Burner Model / Size Selection**

Consider the following when selecting the burner size:

- **Heat Input:** Calculate the required heat input to achieve the required heat balance. The burner air supply option selected will affect available heat output from the burner.
- **Power Supply Frequency:** Burner capacity will vary with power supply frequency (50 Hz or 60 Hz power).
- **Combustion Chamber Pressure:** Consider the effects that large or varying chamber pressures have on burner performance.
- **Altitude:** The maximum burner capacity is reduced by approximately 3% each 1000 feet (300 meters) above sea level.
- **Combustion Air Supply:** Combustion air should be fresh (20.9% O<sub>2</sub>) and clean (without particles or corrosives).
- **Combustion Air Temperature:** Changes in air supply temperature can affect the burner capacity. The combustion air supply temperature should not exceed 250°F.
- **Fuel Type:** Variation in calorific value and density will affect burner performance. Nominal burner performance is based on fuel properties in Table 3.1.

### **Firing Position**

- Vertical down firing
- Vertical up firing
- Horizontal firing

## Burner Configuration

Select configuration. See Figure 3.1.

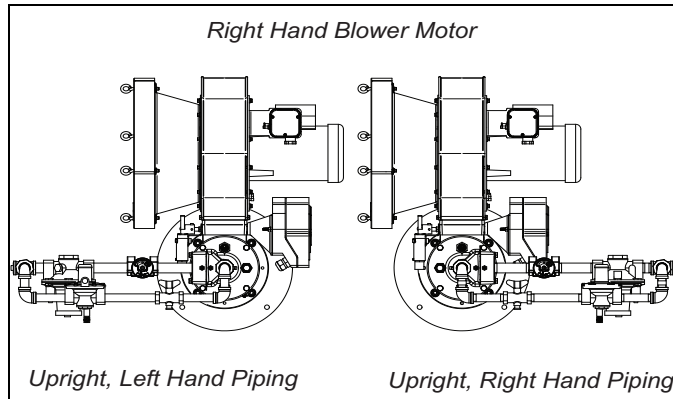

**Figure 3.1 Burner Configuration & Motor Orientation Choice**

## Fuel Type

**Table 3.1 Fuel Type**

Fuel	Symbol	Gross Heating Value	Specific Gravity	WOBBE Index
Natural Gas	CH <sub>4</sub> 90%+	1000 BTU/ft <sup>3</sup> (40.1 MJ/m <sup>3</sup> )	0.60	1290 BTU/ft <sup>3</sup>
Propane	C <sub>3</sub> H <sub>8</sub>	2525 BTU/ft <sup>3</sup> (101.2 MJ/m <sup>3</sup> )	1.55	2028 BTU/ft <sup>3</sup>
Butane	C <sub>4</sub> H <sub>10</sub>	3330 BTU/ft <sup>3</sup> (133.7 MJ/m <sup>3</sup> )	2.09	2303 BTU/ft <sup>3</sup>

BTU/ft<sup>3</sup> @ standard conditions (MJ/m<sup>3</sup> @ normal conditions)

If using an alternative fuel supply, contact Eclipse with an accurate breakdown of the fuel components.

## Pilot Configuration

Winnox burners are equipped with a standard integral bypass pilot. No additional hookups are required to operate this pilot. All bypass regulators are supplied with a vent limiting orifice or a vent protector. For additional configurations contact Eclipse.

## Combustor Type

Select a combustor type based on the application:

**Table 3.2 Recommended Maximum Chamber Temp**

Recommended Maximum Chamber Temperature °F (°C)			
Model	Standard Alloy Tube	High Temp Alloy Tube	Refractory Plug
100, 200	1300° (704°)	1550° (843°)	1800° (982°)
300, 400	1300° (704°)	1550° (843°)	1800° (982°)
500, 600	1300° (704°)	1550° (843°)	1800° (982°)
850	1100° (593°)	1400° (760°)	Not Available

Tube and plug temperatures should be reduced 150°F (65°C) when using propane or butane.

**NOTE:** When using a refractory plug, the customer must provide their own refractory combustion tube set up per Eclipse dimensions, see Datasheet series 111 and Installation Guide 111.

## Air Supply

Select either a combustion air blower mounted directly to the burner body, or a pipe connection type for remote blower operation.

## Control Motor

Select a control motor. Standard control motor options include various models, provided mounted to the burner. Winnox burners can be ordered with control motor bracket and mounting hardware only. Customer supplied control motors must conform to these specifications:

- rotation not to exceed 2 rpm
- minimum torque of 25 in-lb (2,8 Nm)
- 90° stroke
- continuous modulating or high/low modulating control
- reversible direction of rotation
- certain applications may require control motors with a limit switch or switches if:
  - the burner capacity is to be limited to fit an application
  - the chamber is to be fired with positive or negative pressure
  - the chamber pressure is outside the range -1" w.c. to +1" w.c. (-2,5 to 2,5 mbar)
  - there is a need to indicate a high and/or low fire air butterfly valve position

## Limit Switch

Limit switches monitor the position of the integral air butterfly valve. Select high, low, high and low, or no limit switch option. Proper selection is based on preference, control system, and local code.

## Loading Line Type

All Winnox burners have the option of plastic, flexible braided stainless steel or rigid stainless tubing loading line. Selection depends on application and environment.

## Air Pressure Switch

The air pressure switch provides a signal to the monitoring system when there is not enough air pressure from the blower. If a switch is selected, it will be factory mounted.



- Eclipse supports the NFPA regulation requiring, as a minimum standard for main gas shut-off systems, the use of an air pressure switch in conjunction with other system components.

## Pipe Connections

Select the gas pipe connection thread type. The piping, burner gas inlet, and fuel train components are threaded using the customer selected pipe thread option.

## Flame Supervision

Select a flame rod or an ultraviolet (UV) scanner. Both are available on all Winnox burners. If a flame rod is selected, it will be factory mounted in the burner. If a UV scanner is selected, it must be ordered separately. See step 5 for additional information on flame supervision selection.

## Step 2: Packaged Blower Option Selection

**NOTE:** Standard blower options are listed in Price List 111, additional blower options are available through Eclipse. Price and leadtime may vary.

## Power Supply Frequency

Select the 50Hz or 60Hz option. The 50Hz blower motors have IEC frames and are CE marked. The 60Hz motors have NEMA frames.

## Pressure & Flow

Eclipse integrated packaged blowers are designed to provide the required pressure and flow in standard conditions. For information regarding non-standard conditions, please refer to the appropriate datasheet series 111.

## Blower Motor Type

Motor types include various options: voltages, single or three phase, TEFC or automotive duty enclosures.

## Blower Inlet

When selecting an inlet, consider the following:

- amount and size of particles in the air
- sound requirements
- space limitations
- cleanliness requirements of the process

## Blower Configuration

Right-hand blower motor is the standard blower configuration. If left-hand blower motor is required, contact factory. Refer to Figure 3.1.

## Step 3: Control Methodology

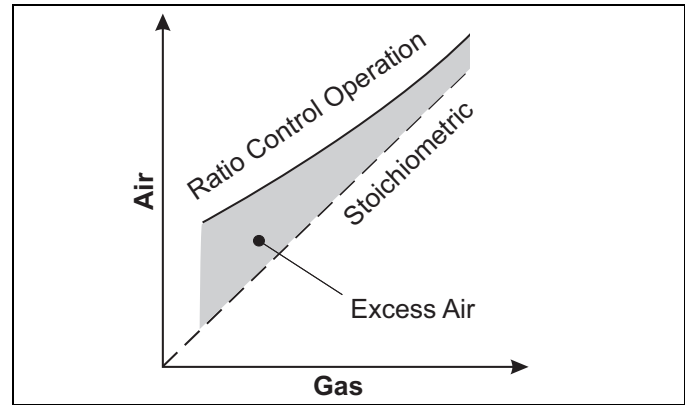

Figure 3.2 Air : Gas Flow

All standard Winnox burners are designed for:

- air : gas ratio controlled combustion
- 40 - 70% excess air at high fire
- higher excess air at low fire

## Burner Control

Winnox burners come with a ratio regulator that maintains the air : gas ratio. An integral minimum fuel bypass line is used to maintain and control a reliable low fire input flow.

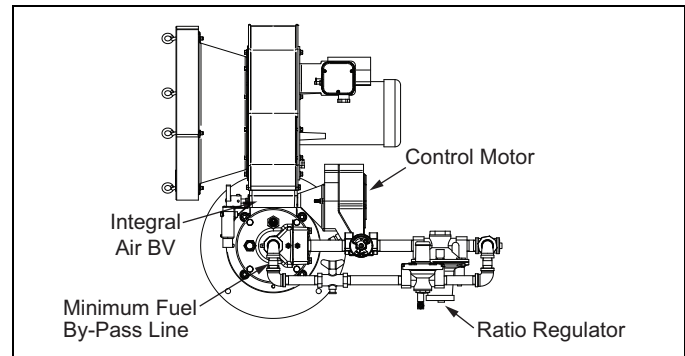

Figure 3.3 Basic Burner Components

- A control signal is sent from a process temperature controller (sold separately) to the control motor. (Contact Eclipse for further information on temperature controllers.)

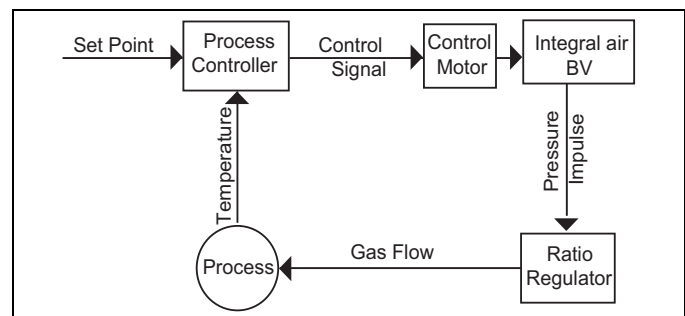

Figure 3.4 Basic Control Loop

- The control motor modulates the integral air butterfly valve which controls the combustion air flow.



- Air pressure in the burner body sends an impulse through the loading line to the ratio regulator.
- The ratio regulator controls the gas flow in proportion to the air flow.



- **Do not use other control methods, such as, a fixed-air control, and do not alter the ratio regulator or burner piping without prior approval from Eclipse. See Installation Guide 111 "Adjustment, Start & Stop" section.**

## **Step 4: Ignition System**

### **Ignition Transformer**

For the ignition system, use a transformer with:

- secondary voltage 6,000 to 8,000 VAC
- minimum secondary current 0.02 amps continuous
- full wave output

### **DO NOT USE the following:**

- twin outlet
- distributor type
- half wave output

### **Trial for Ignition**

The burner may only be lit with low fire settings.

Most local safety codes and insurance requirements limit the maximum trial for ignition time (the time it takes for a burner to ignite). These requirements vary from one location to another; check your local codes and comply to the strictest codes applicable.

The time it takes for a burner to ignite depends on the following:

- the distance between the gas shut-off valve and the burner
- the air : gas ratio
- the gas flow conditions at start-up

### **Ignition Gas Piping**

Winnox burners are capable of ignition with either low fire or bypass start gas.

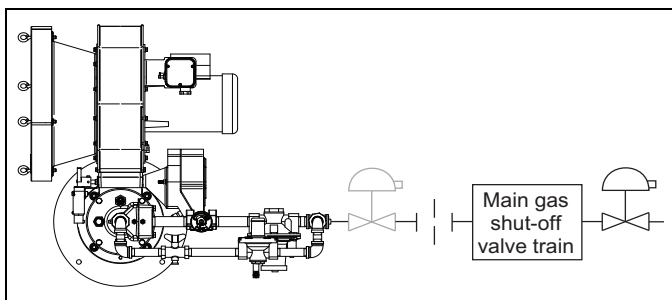

**Figure 3.5 Low Fire Start**

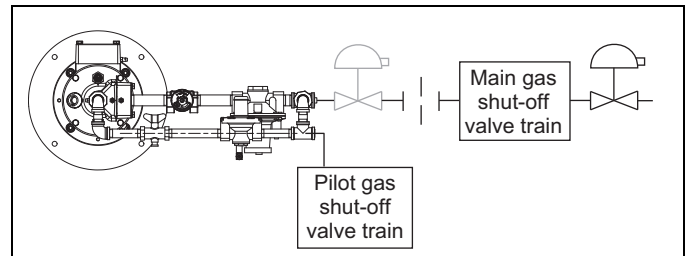

**Figure 3.6 Pilot Start (Optional)**

Piping for pilot start option needs to be sized to accommodate low fire gas flows as stated in Datasheet, series 111.

## **Step 5: Flame Monitoring Control System**

The flame monitoring control system consists of two main components:

- Flame Sensor
- Flame Monitoring Control

### **Flame Sensor**

Two types can be used on a Winnox Burner:

- Flame rod
- UV scanner

Flame rods are available for all Winnox burner sizes. Further information can be found in:

- Info Guide 832

A UV scanner can be used on all Winnox burner sizes.

The UV scanner must be compatible to the flame monitoring control that is used. Refer to the manual of your selected control for proper selection of the scanner.

### **Flame Monitoring Control**

The flame monitoring control processes the signal from the flame sensor and controls the start-up and shut-down sequences.

If other controls are considered, contact Eclipse to determine how burner performance may be affected. Flame monitoring controls that have lower sensitivity flame detecting circuits may limit burner turndown and change the requirements for ignition. Flame monitoring controls that stop the spark as soon as a signal is detected may prevent establishment of flame, particularly when using UV scanners. The flame monitoring control must maintain the spark for a fixed time interval that is long enough for ignition.

### **DO NOT USE the following:**

- Flame monitoring relays which interrupt the trial for ignition when the flame is detected
- Flame sensors which supply a weak signal
- Flame monitoring relays with low sensitivity

**! WARNING**

- A UV scanner can possibly detect another burner's flame if it is in the line of sight, and falsely indicate flame presence. Use a flame rod in this situation. This helps prevent accumulation of unburned fuel which, in extreme situations, could cause a fire or an explosion.

**Step 6: Main Gas Shut-Off Valve Train  
Component Selection**

Eclipse can help in the design of or provide a main gas shut-off valve train that satisfies the customer and complies with all local safety standards and codes set by the authorities within that jurisdiction. Contact Eclipse for further information.

**NOTE:** Eclipse supports NFPA regulations (two gas shut-off valves as a minimum standard for main gas shut-off systems).

**Fuel Flow Measurement**

Eclipse requires a fuel flow measurement device ❶ to ensure proper operation of the Winnox Burner. Eclipse recommendations can be found in the appropriate Winnox Datasheet, series 111.

**Valve Train Size**

Fuel pressure supplied to the ratio regulator inlet must be within the range specified on the Winnox Datasheet, series 111. The valve train should be sized sufficiently to provide the specified pressure. A second main gas pressure regulator ❷ immediately upstream from the burner gas inlet might be necessary to maintain inlet pressure to the burner.

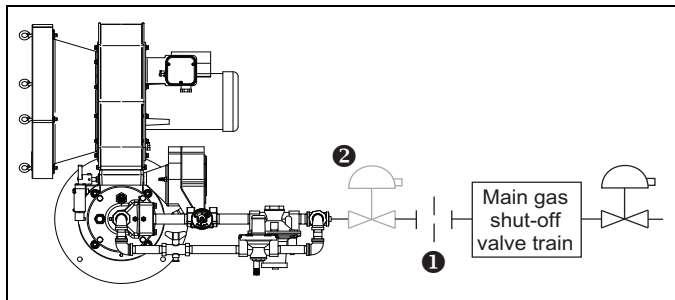

**Figure 3.7 Low Fire Start**

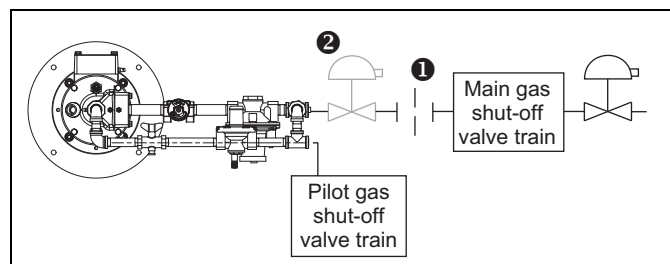

**Figure 3.8 Pilot Start Option**

**! WARNING**

- Do not operate Winnox burners with gas inlet pressure less than the minimum listed on the Winnox Datasheet. Lower gas inlet pressures may cause the ratio regulator to remain fully open at lower inputs as the burner transitions from low to high fire. This could result in the possible accumulation of unburned fuel in the burner which, in extreme situations, could cause a fire or an explosion.

**Step 7: Verify Chamber Design  
Firing Chamber Dimensions**

The Winnox is a low emissions burner that might require a larger firing chamber than a standard burner.

Chamber dimensions are a function of chamber temperature, process air volume and burner input. Contact your Eclipse representative to review your chamber design.

**NOTE:** See the Installation Guide for recommendations on wall and insulation construction when only installing the refractory plug.

**Flame Shielding**

In applications where process air may be flowing perpendicular over the combustor, a metal shroud should be installed around the combustor that is 20% larger than the combustor diameter and with a length that covers the combustor slots by 100 mm (4"). Slot dimensions can be found in Datasheet, series 111.

# Appendix

## Conversion Factors

### Metric to English

From	To	Multiply By
actual cubic meter/h (am <sup>3</sup> /h)	actual cubic foot/h (acfh)	35.31
normal cubic meter/h (Nm <sup>3</sup> /h)	standard cubic foot /h (scfh)	38.04
degrees Celsius (°C)	degrees Fahrenheit (°F)	(°C x 9/5) + 32
kilogram (kg)	pound (lb)	2.205
kilowatt (kW)	Btu/h	3415
meter (m)	foot (ft)	3.281
millibar (mbar)	inches water column ("w.c.)	0.402
millibar (mbar)	pounds/sq in (psi)	14.5 x 10 <sup>-3</sup>
millimeter (mm)	inch (in)	3.94 x 10 <sup>-2</sup>
MJ/Nm <sup>3</sup>	Btu/ft <sup>3</sup> (standard)	26.86







### Metric to Metric



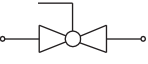
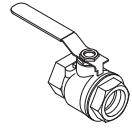
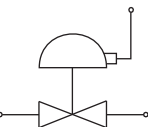
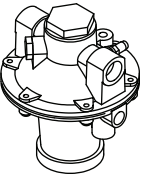

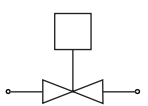
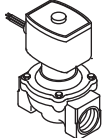

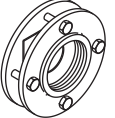

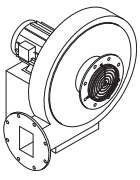

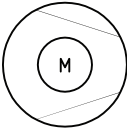
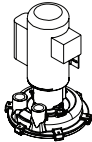
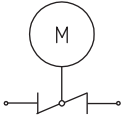
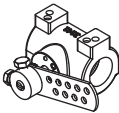
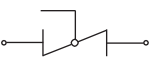
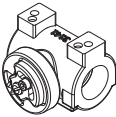
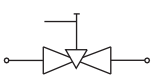

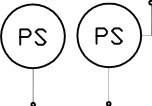
From	To	Multiply By
kiloPascals (kPa)	millibar (mbar)	10
meter (m)	millimeter (mm)	1000
millibar (mbar)	kiloPascals (kPa)	0.1
millimeter (mm)	meter (m)	0.001

### English to Metric

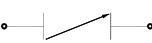
From	To	Multiply By
actual cubic foot/h (acfh)	actual cubic meter/h (am <sup>3</sup> /h)	2.832 x 10 <sup>-2</sup>
standard cubic foot /h (scfh)	normal cubic meter/h (Nm <sup>3</sup> /h)	2.629 x 10 <sup>-2</sup>
degrees Fahrenheit (°F)	degrees Celsius (°C)	(°F - 32) x 5/9
pound (lb)	kilogram (kg)	0.454
Btu/h	kilowatt (kW)	0.293 x 10 <sup>-3</sup>
foot (ft)	meter (m)	0.3048
inches water column ("w.c.)	millibar (mbar)	2.489
pounds/sq in (psi)	millibar (mbar)	68.95
inch (in)	millimeter (mm)	25.4
Btu/ft <sup>3</sup> (standard)	MJ/Nm <sup>3</sup>	37.2 x 10 <sup>-3</sup>

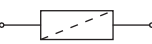
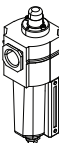
# System Schematics

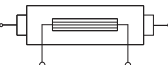
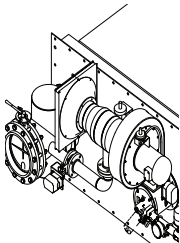
Symbol	Appearance	Name	Remarks	Bulletin/ Info Guide
		Gas Cock	Gas cocks are used to manually shut off the gas supply.	710
		Ratio Regulator	A ratio regulator is used to control the air/gas ratio. The ratio regulator is a sealed unit that adjusts the gas pressure in ratio with the air pressure. To do this, it measures the air pressure with a pressure sensing line, the impulse line. This impulse line is connected between the top of the ratio regulator and the burner body.	
		Main Gas Shut-Off Valve Train	Eclipse strongly endorses NFPA as a minimum.	790/791
		Pilot Gas Valve Train	Eclipse strongly endorses NFPA as a minimum.	790/791
		Automatic Shut-Off Valve	Shut-off valves are used to automatically shut off the gas supply on a gas system or a burner.	760
		Orifice Meter	Orifice meters are used to measure flow.	930
		Combustion Air Blower	The combustion air blower provides the combustion air to the burner(s).	610

Symbol	Appearance	Name	Remarks	Bulletin/ Info Guide
		Hermetic Booster	Booster is used to increase gas pressure.	620
		Automatic Butterfly Valve	Automatic butterfly valves are typically used to set the output of the system.	720
		Manual Butterfly Valve	Manual butterfly valves are used to balance the air or gas flow at each burner.	720
		Adjustable Limiting Orifice	Adjustable limiting orifices are used for fine adjustment of gas flow.	728/730
		Pressure Switch	A switch activated by rise or fall in pressure. A manual reset version requires pushing a button to transfer the contacts when the pressure set point is satisfied.	840
		Pressure Gauge	A device to indicate pressure.	940
		Check Valve	A check valve permits flow only in one direction and is used to prevent back flow of gas.	780
		Strainer	A strainer traps sediment to prevent blockage of sensitive components downstream.	
		Flexible Connector	Flexible connectors isolate components from vibration, mechanical, and thermal stresses.	
		Heat Exchanger	Heat exchangers transfer heat from one medium to another.	500
		Pressure Taps	Pressure taps measure static pressure.	

**Automation and Control Solutions**

Honeywell International Inc.  
1985 Douglas Drive North  
Golden Valley, MN 55422  
[customer.honeywell.com](http://customer.honeywell.com)

® U.S. Registered Trademark  
© 2016 Honeywell International Inc.  
32-00056-01 M.S. 09-16  
Printed in United States

