

*Innovative Combustion Solutions Worldwide*

# AIR HEAT BURNERS

*“The AH Family”*

- *Process Air Heating*
- *Makeup Air Heating*

**ECLIPSE<sup>®</sup>**  
Innovative Thermal Solutions



# AN INDUSTRY STANDARD

## Performance.

Our patented "AH" Burner—the foundation of our "AH" family—features an integral blower and steel case for unmatched air heating performance:

- Low  $\text{No}_x$ , CO and aldehydes.
- Process airstream velocities from 250 to 6000 fpm, (1.5 to 30 m/s) no profiling required.
- Up to 40:1 gas turndown.
- Inputs up to 1,000,000 Btu/hr. (293 kW)
- As little as 10% excess air at high fire; no oxygen is required from the process airstream.
- Reliable operation year after year with minimal maintenance.
- Burns natural gas or propane; butane versions available.

## Versatility.

We've modified this basic design to create a family of burners capable of handling nearly any air heating need. Variations include:

- "RAH" Burners—For recirculating air systems. A remote blower supplies combustion air; no oxygen is required from the process airstream. The steel case shields the gas manifold from process airstream temperatures.
- "AH-O" Burners—Open back design uses process air for combustion.
- "AH-MA" Burners—for make-up air heating.

Burner construction can be modified to meet a wide range of temperature requirements.

## Options.

No other air heat line offers this many possibilities:

- Line, tee, and cross sections allow countless geometric designs; required inputs and heat distributions are easily attained.
- Optional flame monitoring and gas feed end plates simplify gas control system design.
- Burners can be ordered stripped or completely packaged, wired, and piped, ready to install and fire.
- Burner packages can be mounted on side-plates or in duct sections to simplify installation.
- In-duct, slot-fired, or sealed wall mounting options are available.

## Excellent Flame Stability.

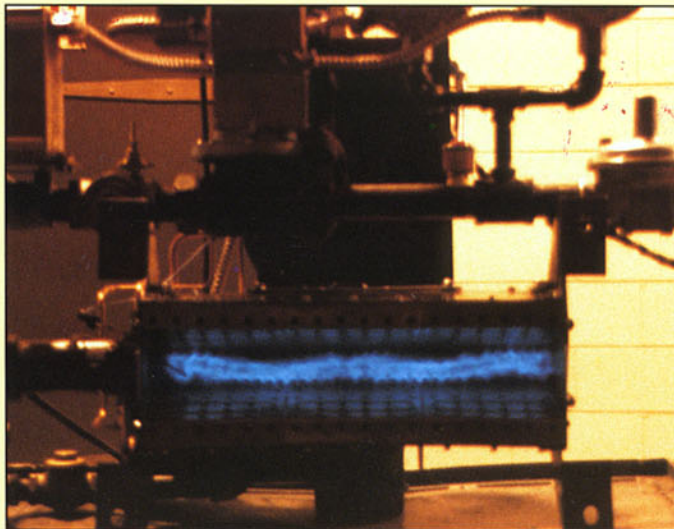

**Low Fire**—Completely enclosed within the burner's steel case, the low fire flame is protected from fluctuations in the process airstream. A partial premix provided by the low fire check valve ensures exceptional flame stability at 40:1 turndown.

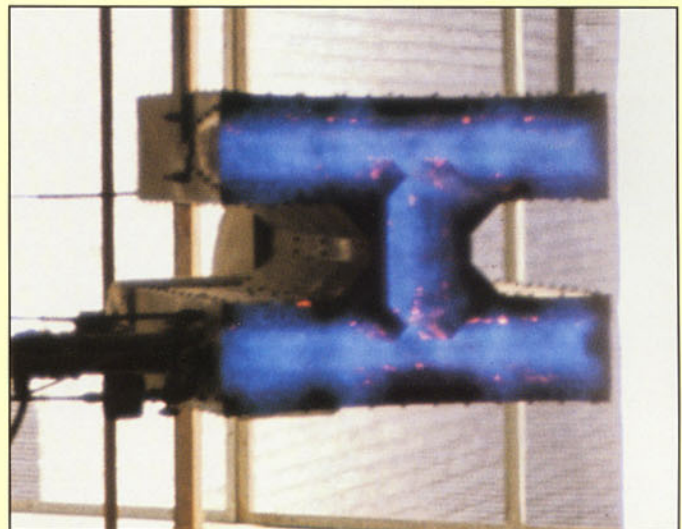

**High Fire**—With the base of the flame protected by the burner's steel case, flame stability is excellent at process airstream velocities from 250 to 6000 fpm (1.5 to 30 m/s). "AH" and "RAH" models operate with as little as 10% excess air and require no oxygen from the process airstream.



# BY DESIGN

**Combustion Air Blower**—Supplies air to models "AH" and "RAH"; no oxygen is required from the process airstream.

**Steel Case**—Provides excellent flame stability regardless of airstream velocity; reduces thermal stress on manifold for long burner life.

**Low Fire Check Valve**—Provides partial premix at low fire for excellent flame stability at 40:1 turndown.

**Air Diffuser Plate**

**Cast Iron Manifold**

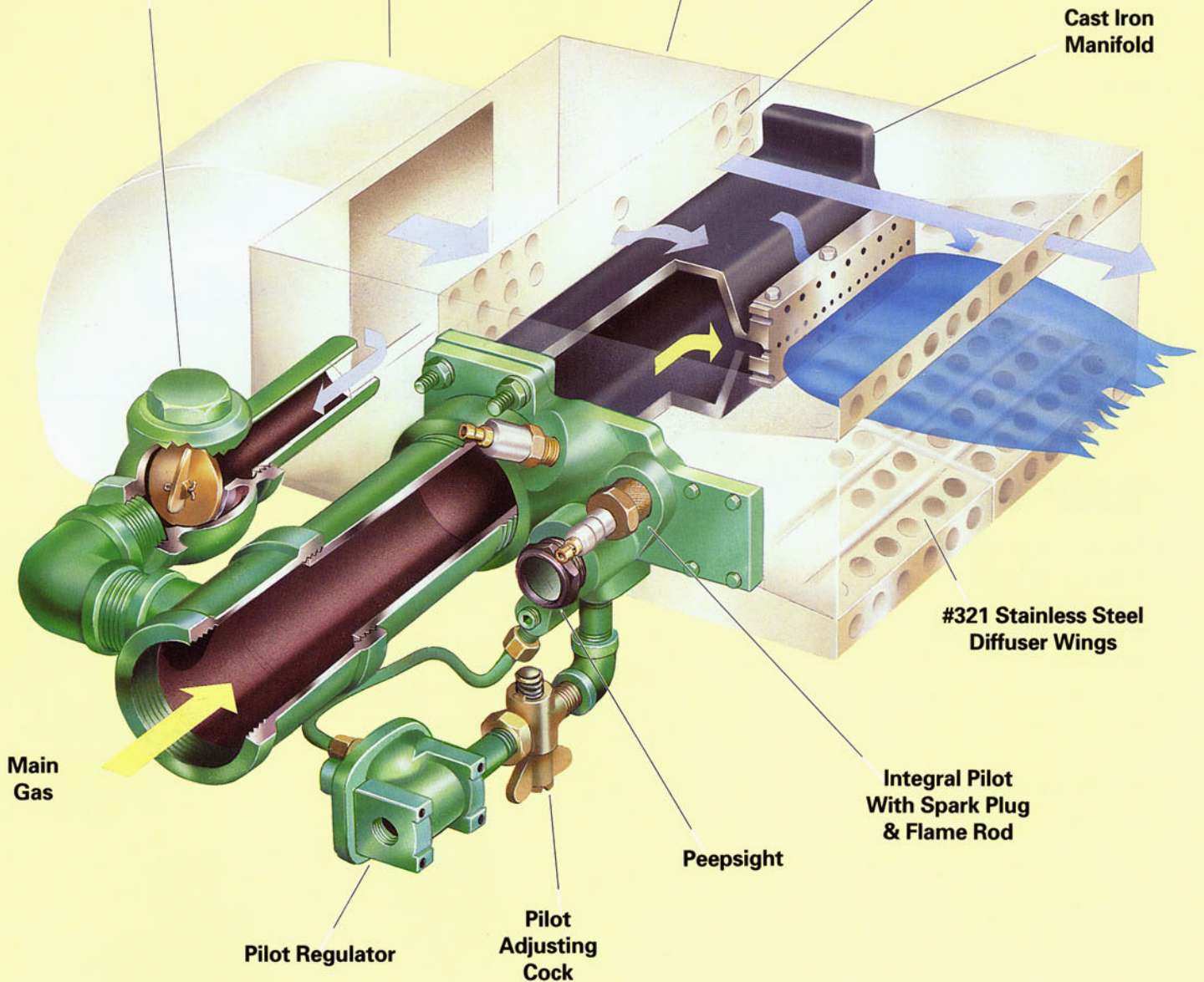

# THE "AH" FAMILY

## "AH" Burners

- Integral blower; no oxygen required from the process airstream.
- 250 to 6000 fpm (1.5 to 30 m/s) duct velocity; no profiling required.
- Up to 1,000,000 Btu/hr./ft. (293 kW)
- Up to 40:1 Turndown.
- Bottom mounted blower available for tight spaces.

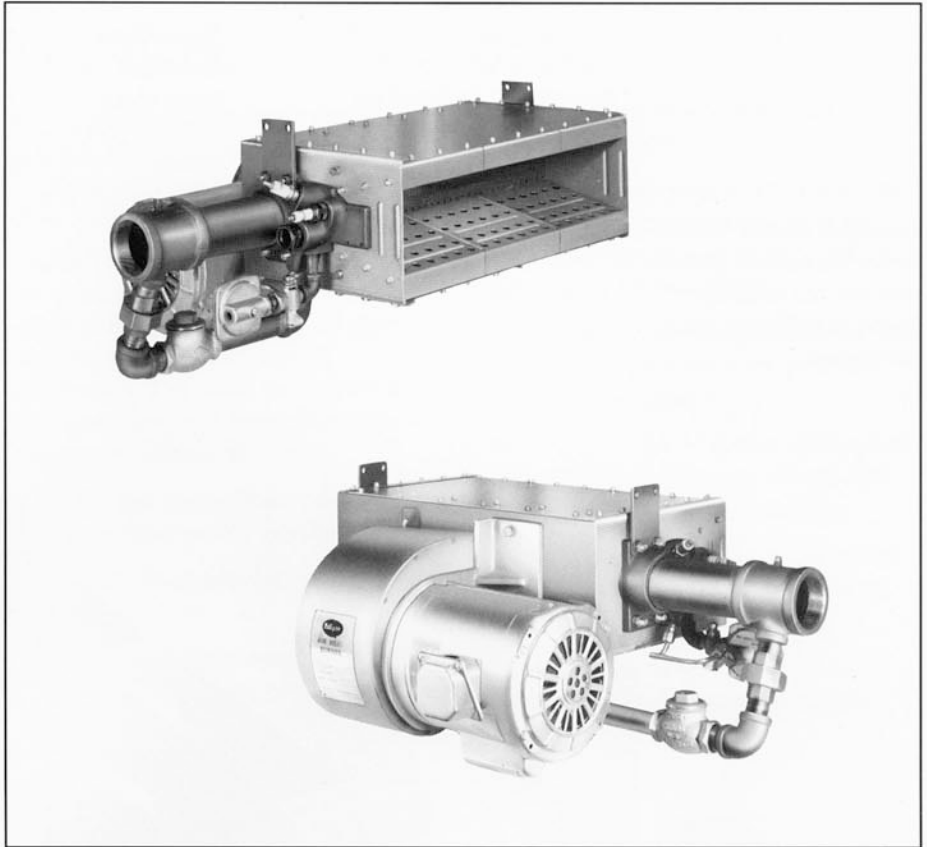

## "RAH" Burners

- For recirculating systems. A remote mounted blower supplies combustion air; no oxygen is required from the process airstream.
- 250 to 6000 fpm (1.5 to 30 m/s) duct velocity; no profiling required.
- Up to 1,000,000 Btu/hr./ft. (293 kW)
- Up to 40:1 Turndown.
- Air temperatures past the burner up to 750°F (400°C) downstream of the burner up to 1500°F (800°C). Higher temperatures possible with specially adapted burners.

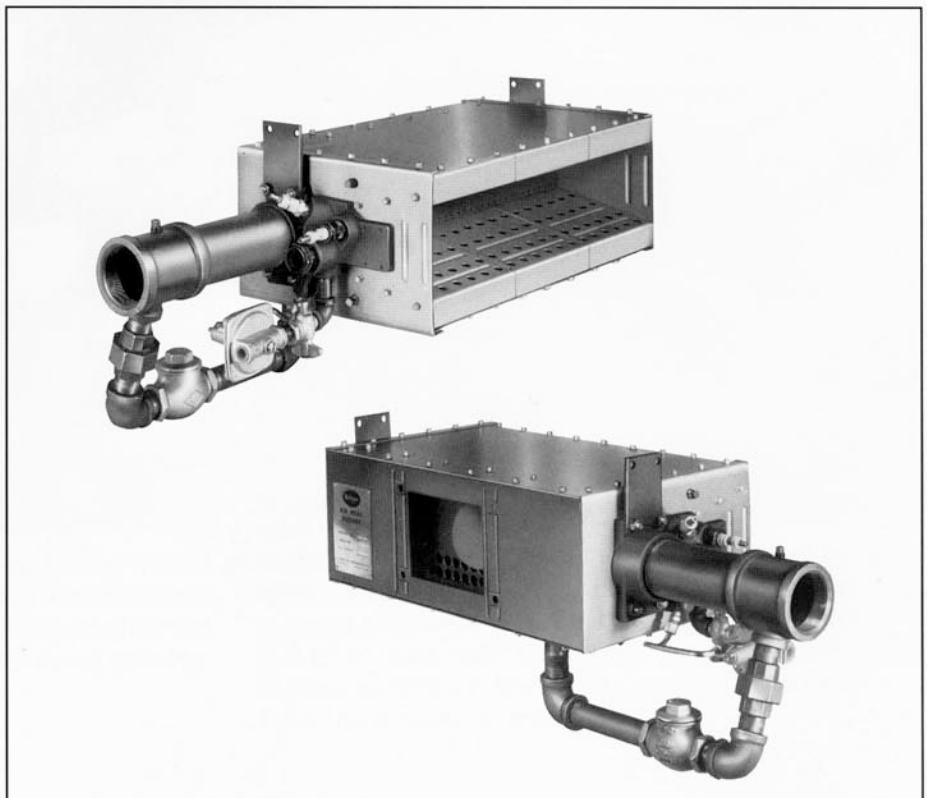

## "AH-O" Burners

- Open back design uses process air for combustion; 18% minimum O<sub>2</sub> required in airstream.
- Requires 0.4" to 1.0" (10 mm to 25 mm)  $\Delta P$  airstream pressure drop across burner.
- Up to 1,000,000 Btu/hr./ft. (293 kW) depending on airstream velocity
- Up to 40:1 Turndown.
- Air temperatures past the burner up to 750°F (400°C) downstream of the burner up to 1500°F (800°C). Higher temperatures possible with specially adapted burners.

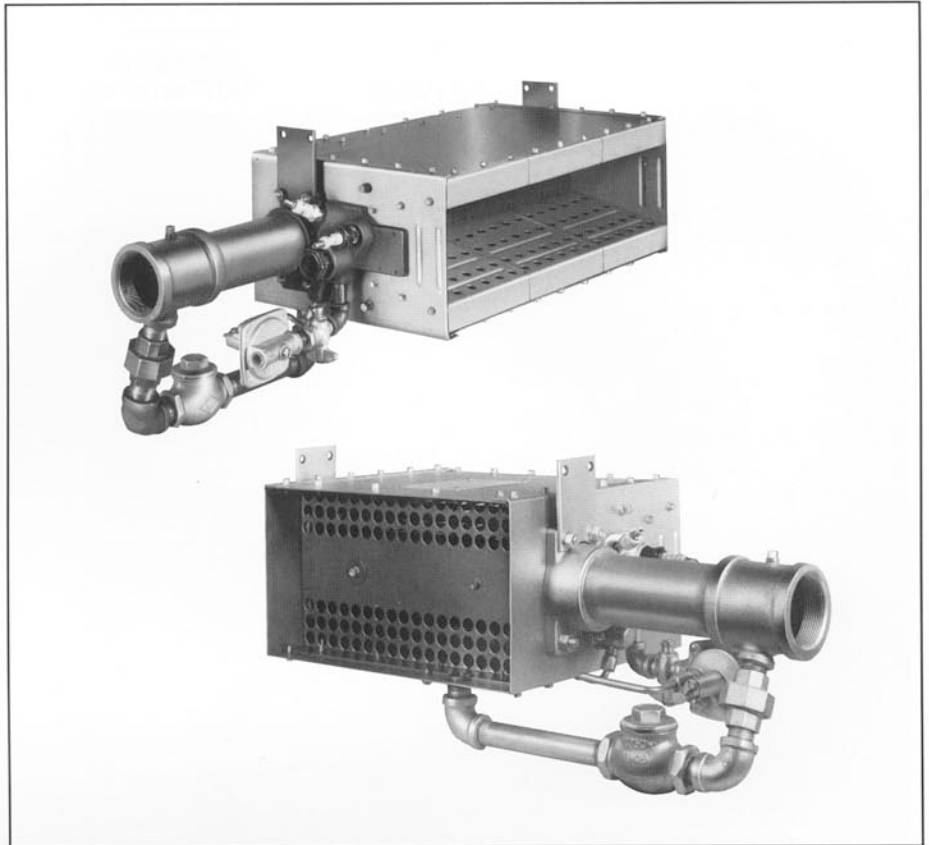

## "AH-MA" Burners

- Designed for makeup air heating.
- Requires 0.4" to 1.0" (10 mm to 25 mm)  $\Delta P$  airstream pressure drop across burner.
- Up to 800,000 Btu/hr./ft. (234 kW), depending on airstream velocity.
- Up to 30:1 Turndown.

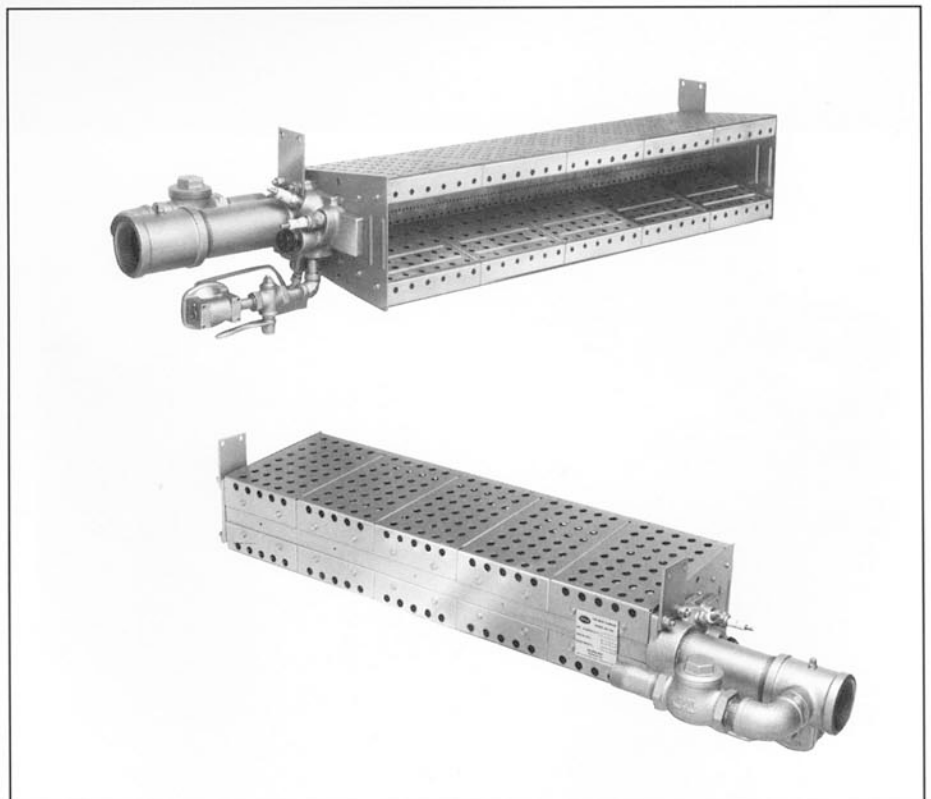



# OPTIONS

## Configurations.

All Eclipse heat burners can be supplied in line, tee, or cross sections. By combining these sections, nearly any burner configuration can be designed. Pictured is an "RAH" array capable of 20 million Btu/hr./5862 kW.

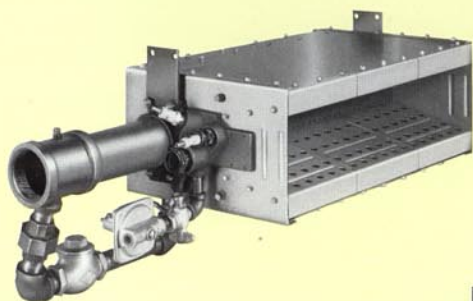
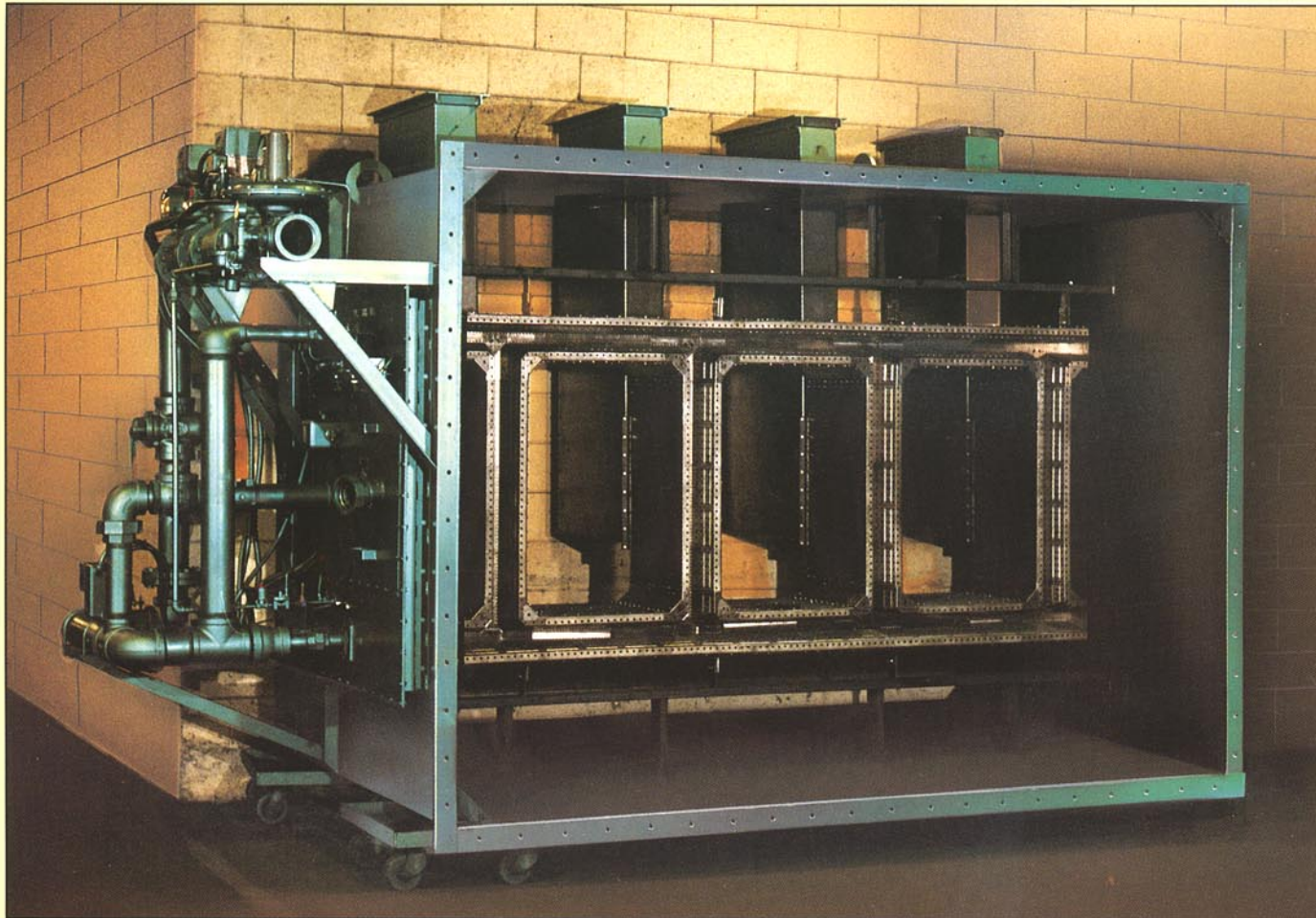

**Line Sections**

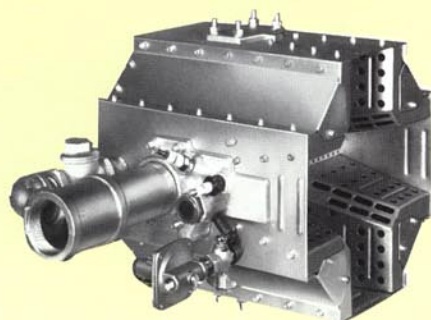

**Cross Sections**

**"T" Sections**

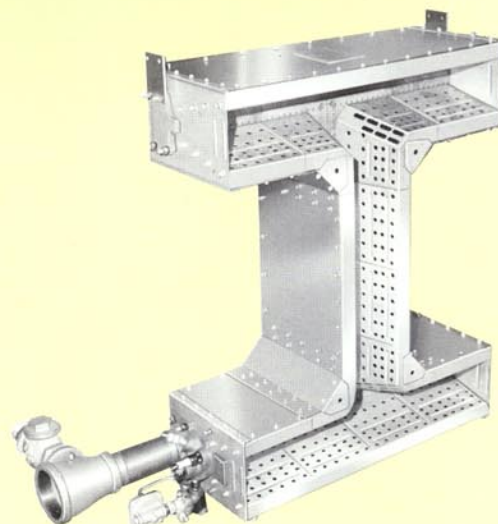



## Packaging Choices.

Eclipse can design a control system to your specifications, pipe and wire it to the burner, and mount the package on any desired support structure—customer supplied or fabricated in our plant. Following are standard packages frequently ordered with FM, IR, or NFPA type valve trains.

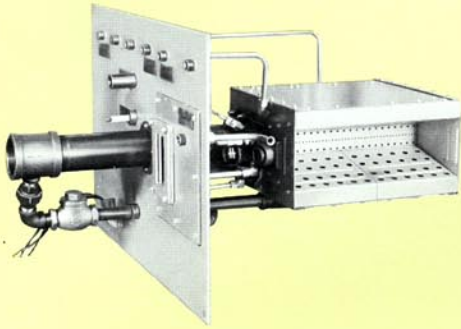

**Side Plates**

## "Heat Paks"

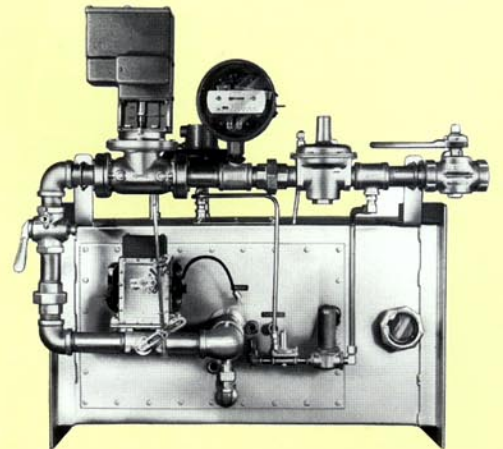
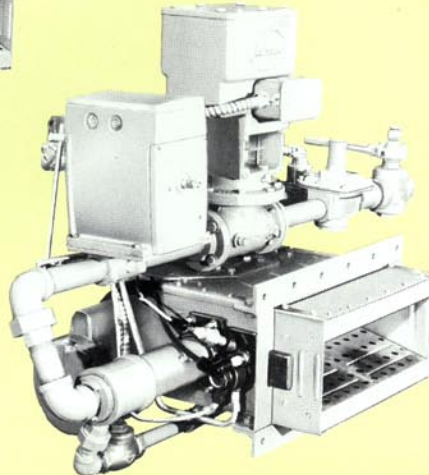

**Ducts**

## Packaging Choices.

Coupled with our high efficiency heat exchangers, Eclipse air heat burners make ideal indirect air heaters for applications requiring hot air free of combustion exhaust products.

This indirect air heater is used by a pharmaceutical company to dry white powders. Steam coils were inefficient and incapable of reaching the required 220°F (104°C) operating temperature, and direct-fired heaters discolored the powder.

The Eclipse indirect air heater supplies plenty of clean, 220°F (104°C) air at efficiencies of 86% in winter and 91% in summer.

With our wide selection of burners and heat exchangers, we can design high efficiency indirect air heaters for most industrial applications.





# OTHER AIR HEATING BURNERS FROM ECLIPSE

In addition to the "AH" burner family described in this brochure, Eclipse also offers many other types of air heating burners. The following two burners are frequently specified for industrial process air heating.



**Mark IV Burners**

- Gas, oil, or combination.
- Stripped or fully packaged.
- Inputs to 5 million Btu/hr./1466 kW



**Ratiomatic Burners**

- Burns natural gas or propane without internal change.
- Inputs to 20 million Btu/hr./5862 K, 60:1 turndown.
- Refractory block or firing tube.

## SINGLE SOURCE SUPPLY

Eclipse offers a comprehensive line of combustion equipment, as well as the knowledge to apply it. We can engineer and construct complete systems, or supply all of the components to the customer for final assembly.

### Flame Monitoring Equipment



- UV scanners & flame rods.
- Flame monitoring relays.
- Control panels.

### Instrumentation

**Process Temperature Controllers**



**Chart & Strip Recorders**

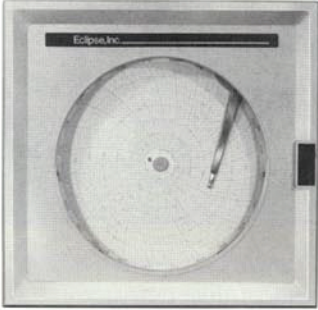

### Valves & Valve Trains

